

HARI STYLE OF ACUPUNCTURE

IPSUM ESSE

Takayuki Koei Kuwahara Lic. Ac.
President of The Hari Society

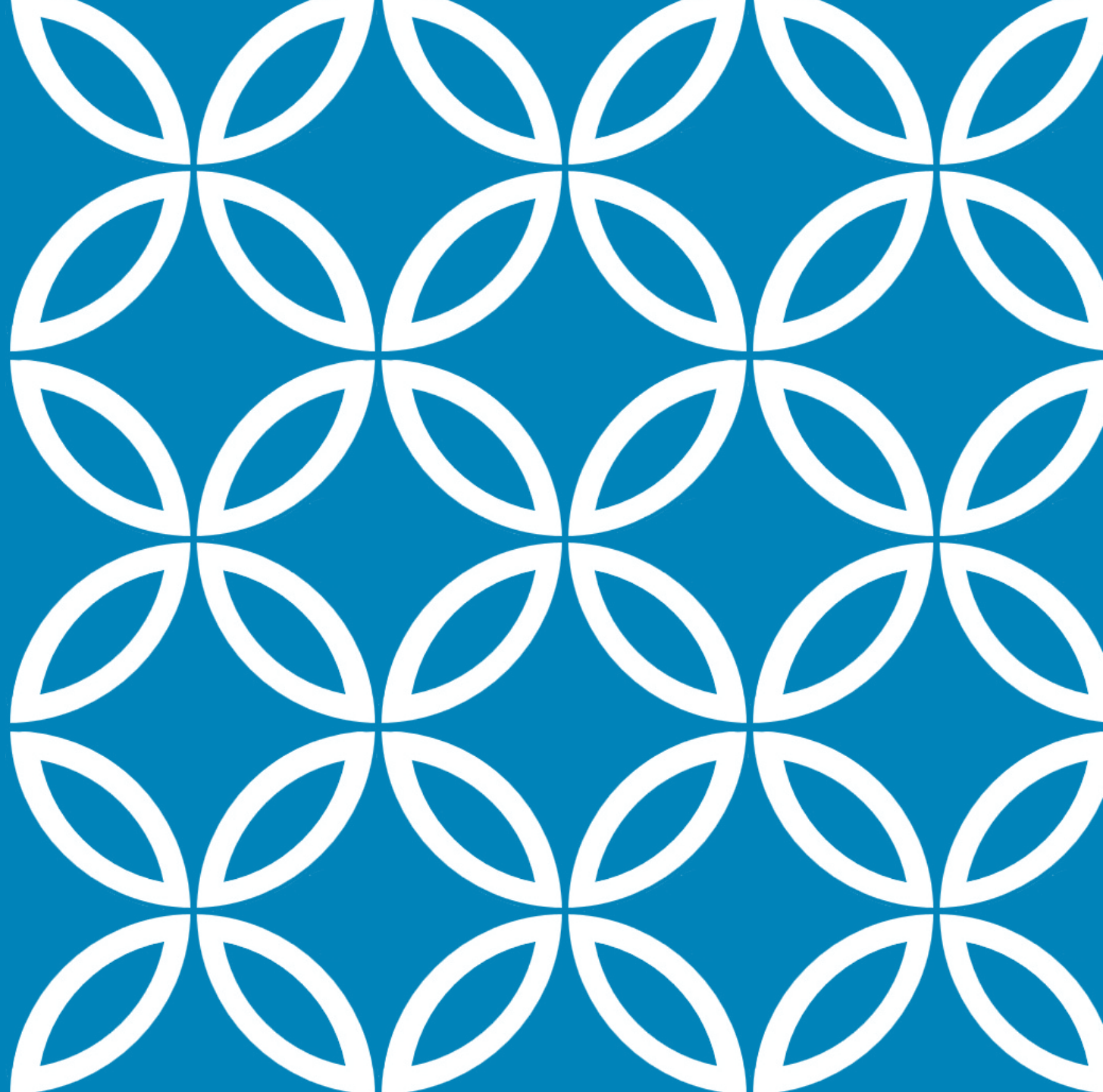

* **HARI**
DEFINITION
(1)

HARI is known as

Traditional Japanese Medicine based on pulse dx. and
Kami.

It involves a clinical reading called **SHŌ/AKASHI**.
Treatment is effected with **Ho** and **Sha** techniques
using **hari** and **okyū**.

(**AKASHI**/pattern of imbalance in the five phases/One
sprints & Four souls and its tx. order).

Meridians points serve as loci for both diagnosis and treatment.

* HARI

DEFINITION

(2)

(1) PRIMARY
SHO

(2) SECONDARY
SHO

HARI consists of two steps of SHO

(1) is on

Space Will (One spirit \Rightarrow 4 Souls)

(2) is on Pathological Minmen effects in
body w/the Ja-Ki.

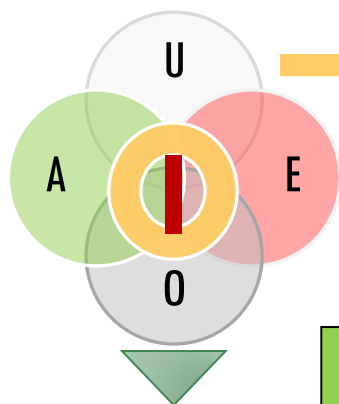

Heaven Ki, **Light** / Space Will

Endogenous
Excessive Earthly Desire

Exogenous
EPI, Food, Drink, Fatigue, ...

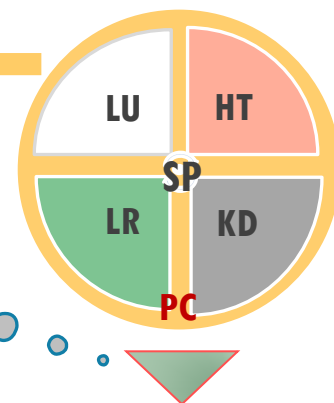
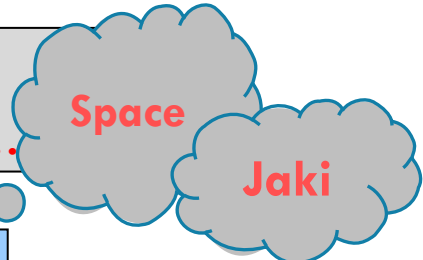

(1) Yin disease/Space

(2) Yang disease/Time

Ōki Jitsu → Fond of Life

Jaki-Jitsu → Tough Lifestyle

Constitutional Factor / 4 Souls < I Sprit **Process of Creation** Pathological Deficient & Excess **Effects from Jaki**

Mother Sounds (1) Primary SHO

Eight Father Rhyme Meridian

(2) Secondary SHO

Generation of Deficiency, Excess

Deficiency or Excess of Ki, Blood, Fluid

U	LU def.
O	KD def.
A	LR def.
E	HT.Pc def.
I	SP def.

Essential Ki (4 Souls) Def. & Excess (Ōki-Jitsu) in Generating Cycle

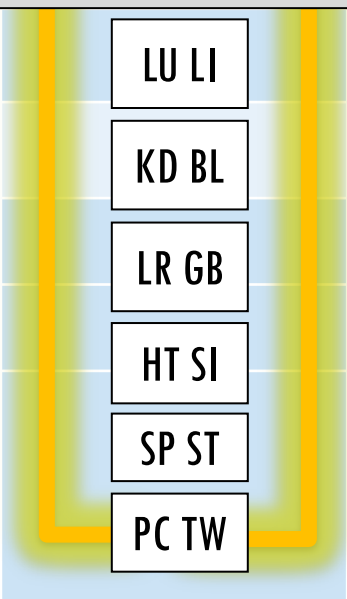

Pathological process with Def. & Excess type Jaki-Jitsu on yang M. & Controlling Cycle

Ki
Fluid
Blood
Fire/Heat-Cold
Ki (Space will), Blood, Fluid

Occurrence of **cold or heat** symptomology due to deficiency or excess of HT and PC

Pressure Pain
Resistance
Cold, Heat
Indurations
Depressions
Protuberances
Dampness, Dryness

Symptoms

Flow Chart: Hari w/ EV + Shigo 03232023

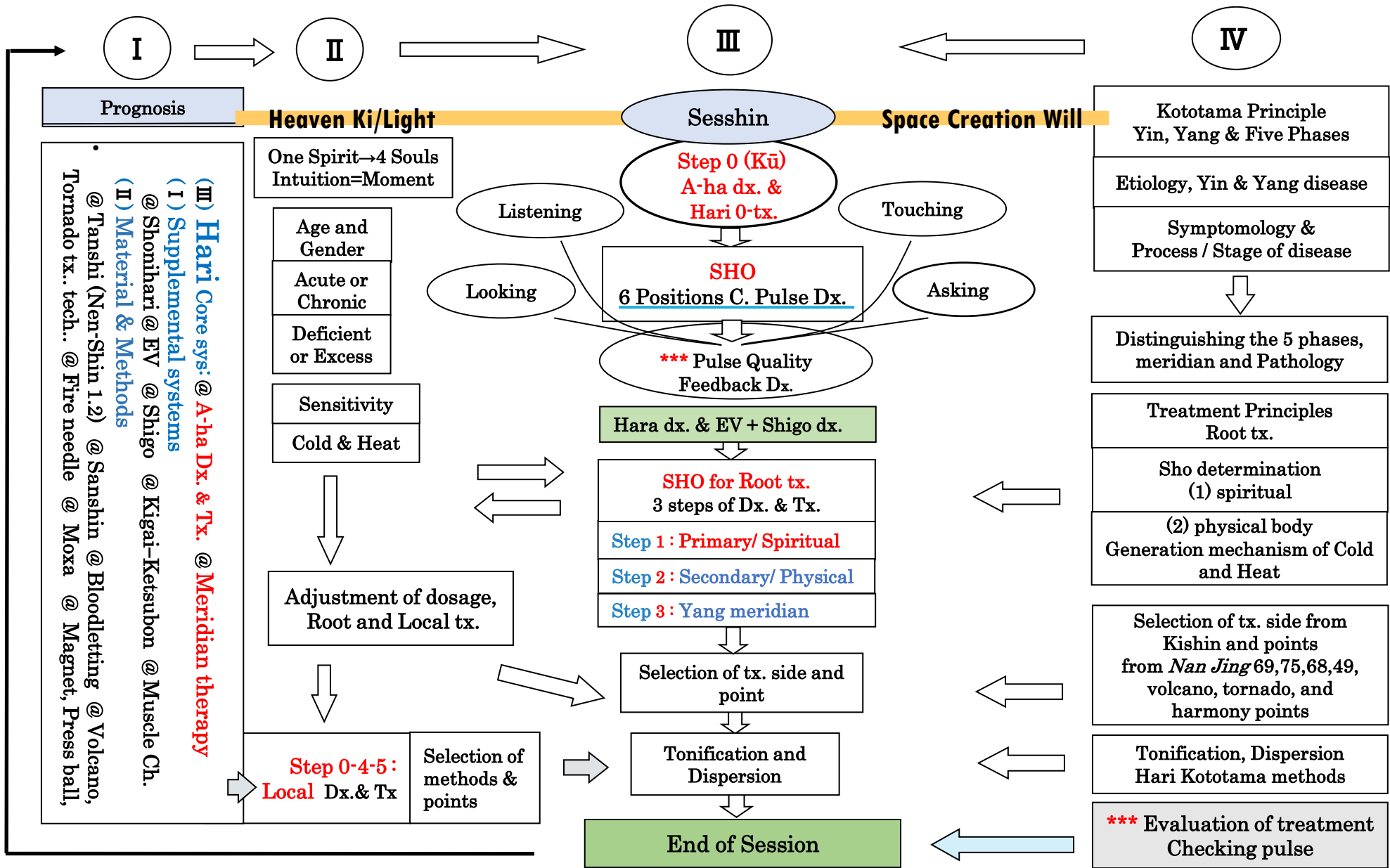

$\sqrt{-1}$

IPSUM ESSE

HARI
A THING THAT IS
IMPORTANT.

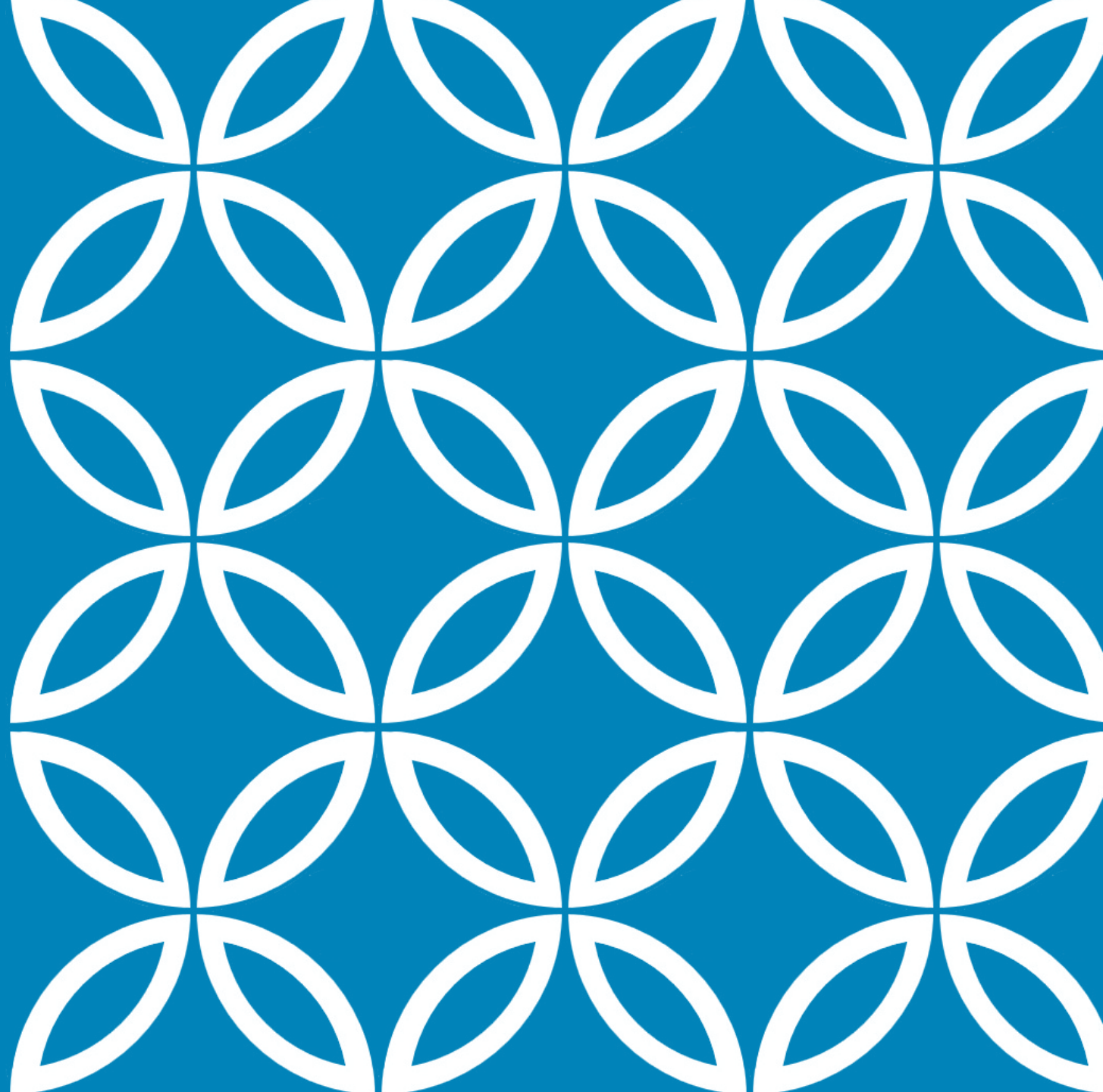

IPSUM ESSE/ KAMI

$$\sqrt{-i}$$

$(\sqrt{-i})^2 = -1$ 反物質
Antimatter

$$(\sqrt{-i})^2 = -1$$

$(\sqrt{-i})^4 = +1$ 物質
Matter

$$(\sqrt{-i})^4 = +1$$

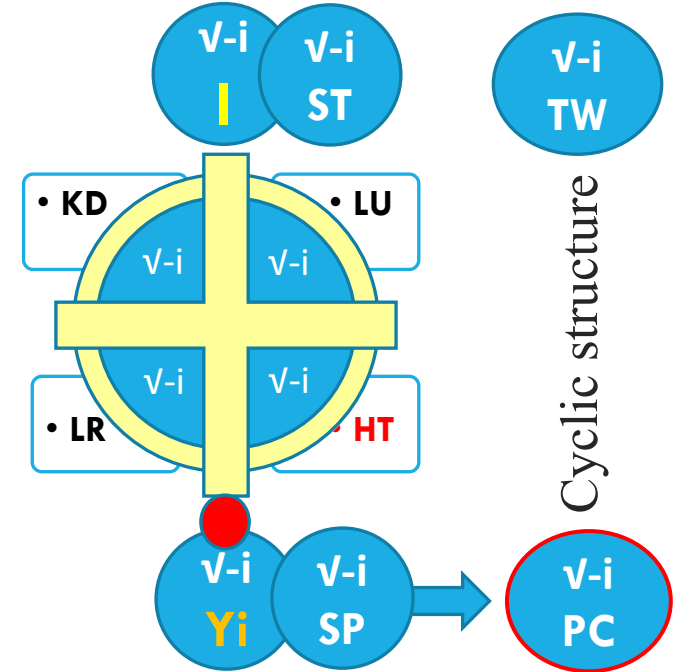
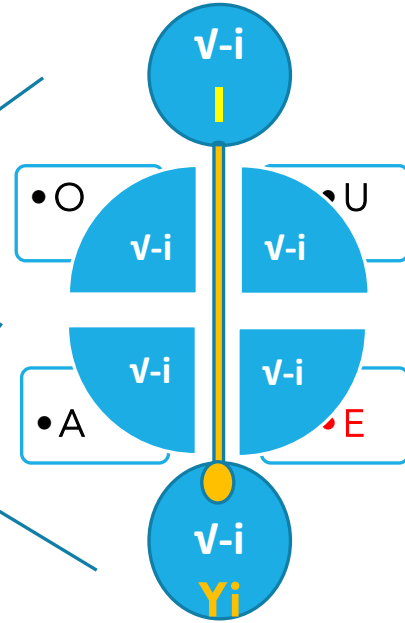

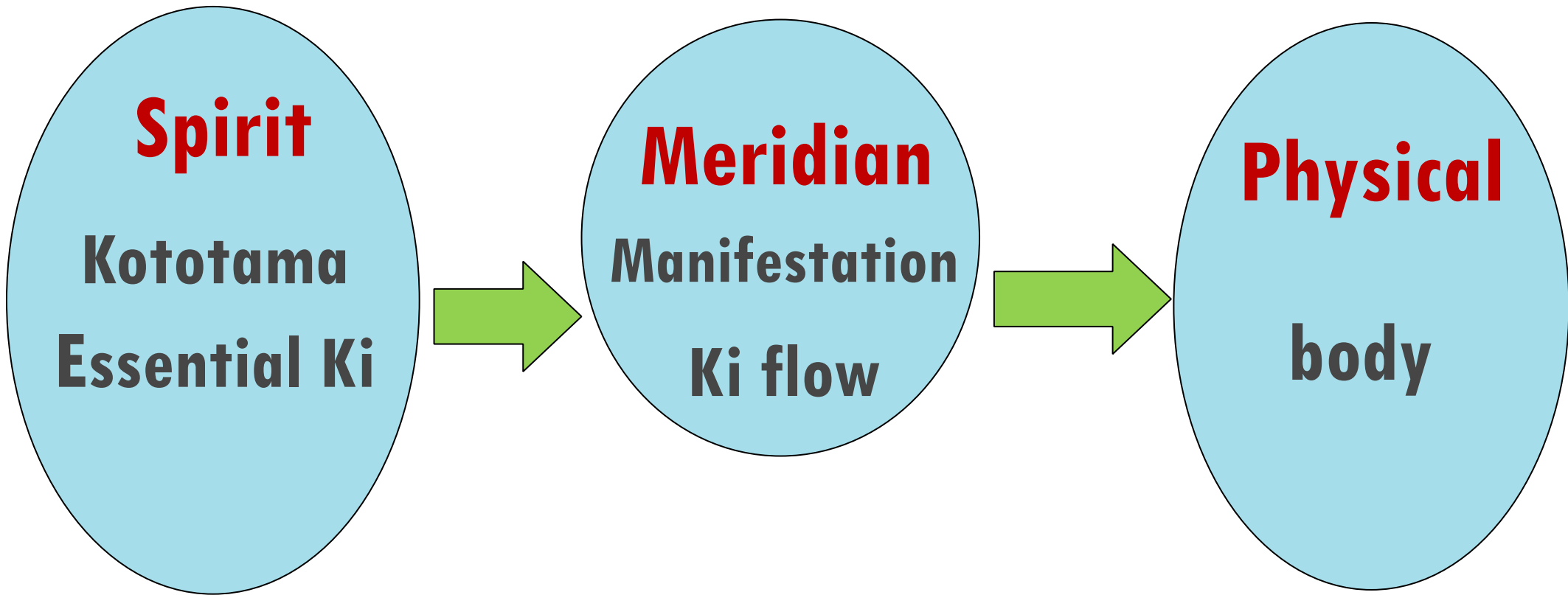

Universe of congenital structure

Acquired Structure

(A) ∞ ∞ ∞ ∞ (Eight Father Ki Rhyme) ∞ ∞ ∞ ∞ **(WA)**

***HARI**

Spirit

ONE Spirit

⇒ Four Souls “Character w/Senses, Mind”

**THREE
CORNERSTONES
OF HARI
PRACTICE**

Meridian: Time

Ki (as “Breath”) flow/process of creation
between the Universe of Congenital to Acquired
Structure

Physical: Space

Pathological effects on Physical Body

Meimon (life of gate) PC-Ki: and TW

* **HARI**

(1)

SPIRIT



A) **Quality:**

Brightening the spirit with Enlightenment.

(2)

KI-BREATHE



B) **Quantity:**

Ki flow/ undulation in proper (Mind-Body **Posture&Use**) with
(**Tanden/Kundalini**) **breath**

Breathe Power of the creation

(3) PATHOLOGICAL

&

JAKI

EFFECT ON BODY



C) **Pts. w/ *Methods:**

It based on understanding of the Pathological effect (Ki, Fluid, Blood) Meimon with Jaki.

* **HARI**
KI FEEDBACK
METHODS

- WITH
1. PULSE QUALITY
 2. 6TH - 7TH SENSE

:

1. ST Ki quality dx. and Sense dx..
 - How to detect abnormal and correct Ki in pulse
2. Feedback method
 - Pulse + Sense dx. can be used as a feedback method for assessing the effectiveness of the tx. as it is being given.

HARI
TECHNIQUES :

HO
SHA

HO:

Nenshin(1) Tonification for Life force

SHA:

**Nenshin(2) w/ (*Eight Father Ki Rhyme)
Dispersion for Jaki.**

PRINCIPLES OF KOTOTAMA

Ancient Five Phases

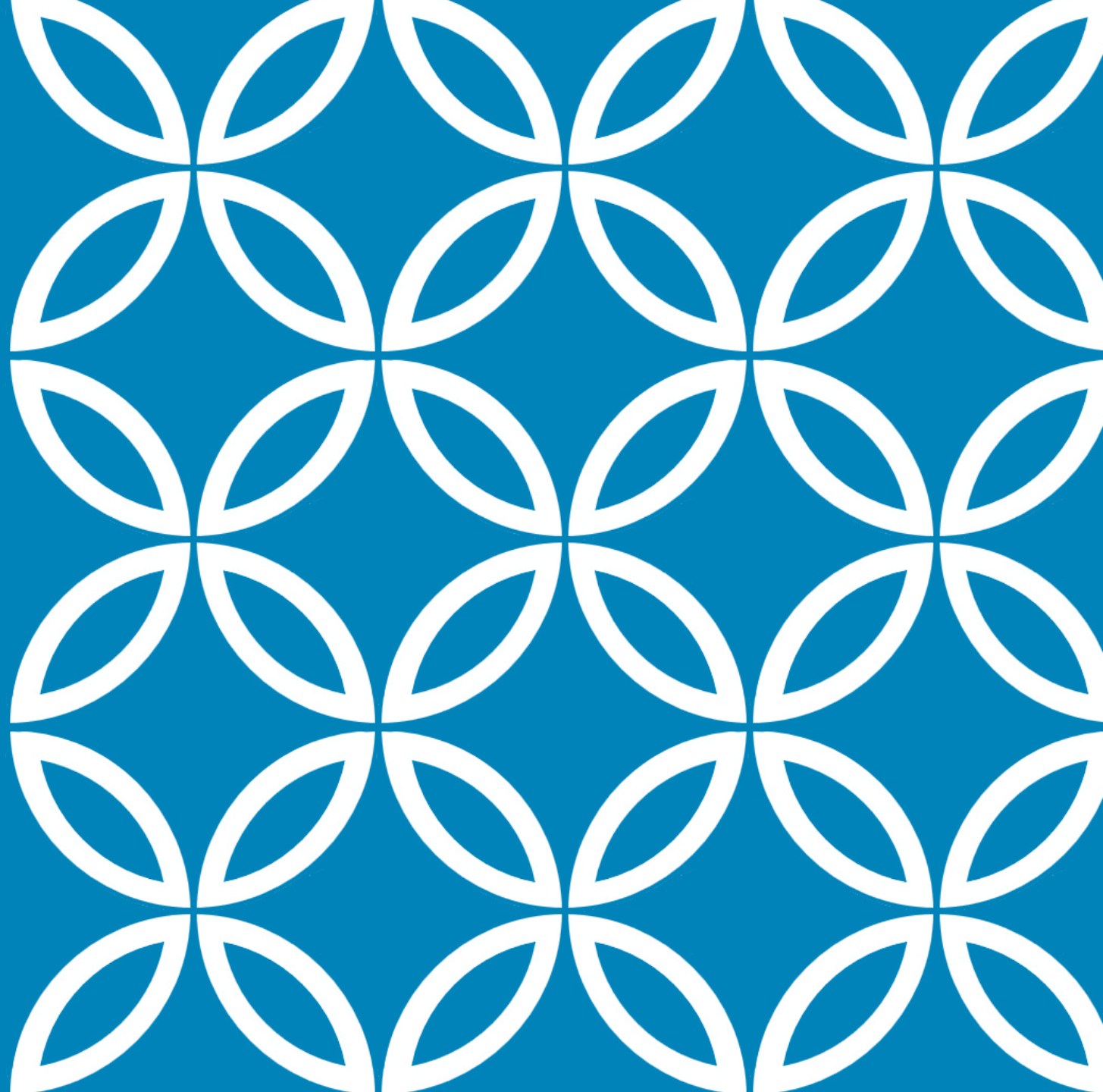



**ESSENCE
OF HARI**

KOTOTAMA

One Spirit

is

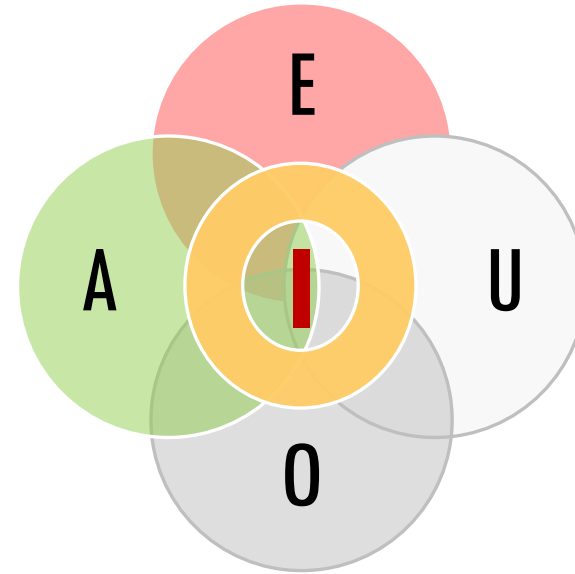

Four Souls

BASIC ORDER OF GENERATION

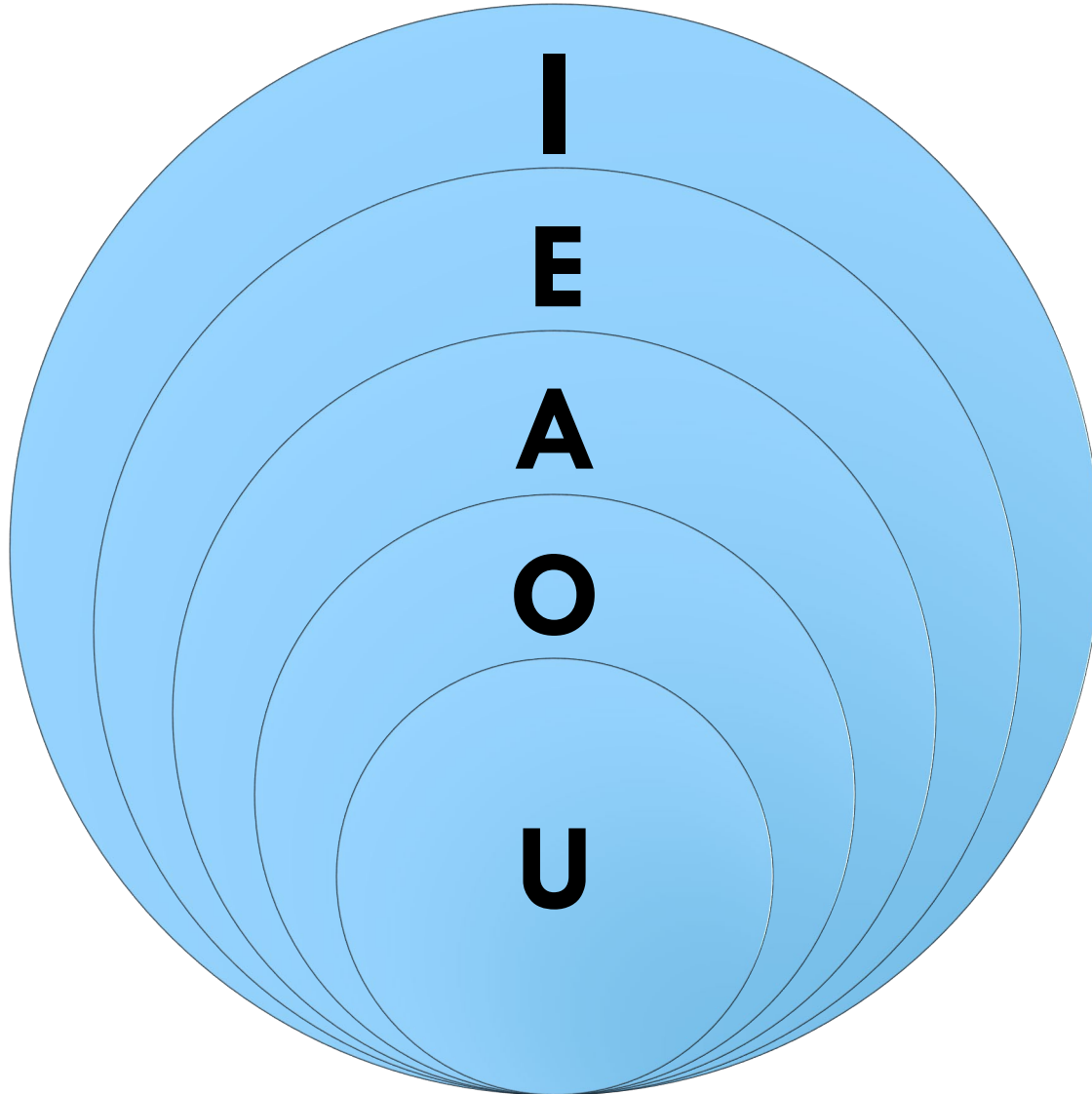

Earth

Fire

Wood

Water

Metal

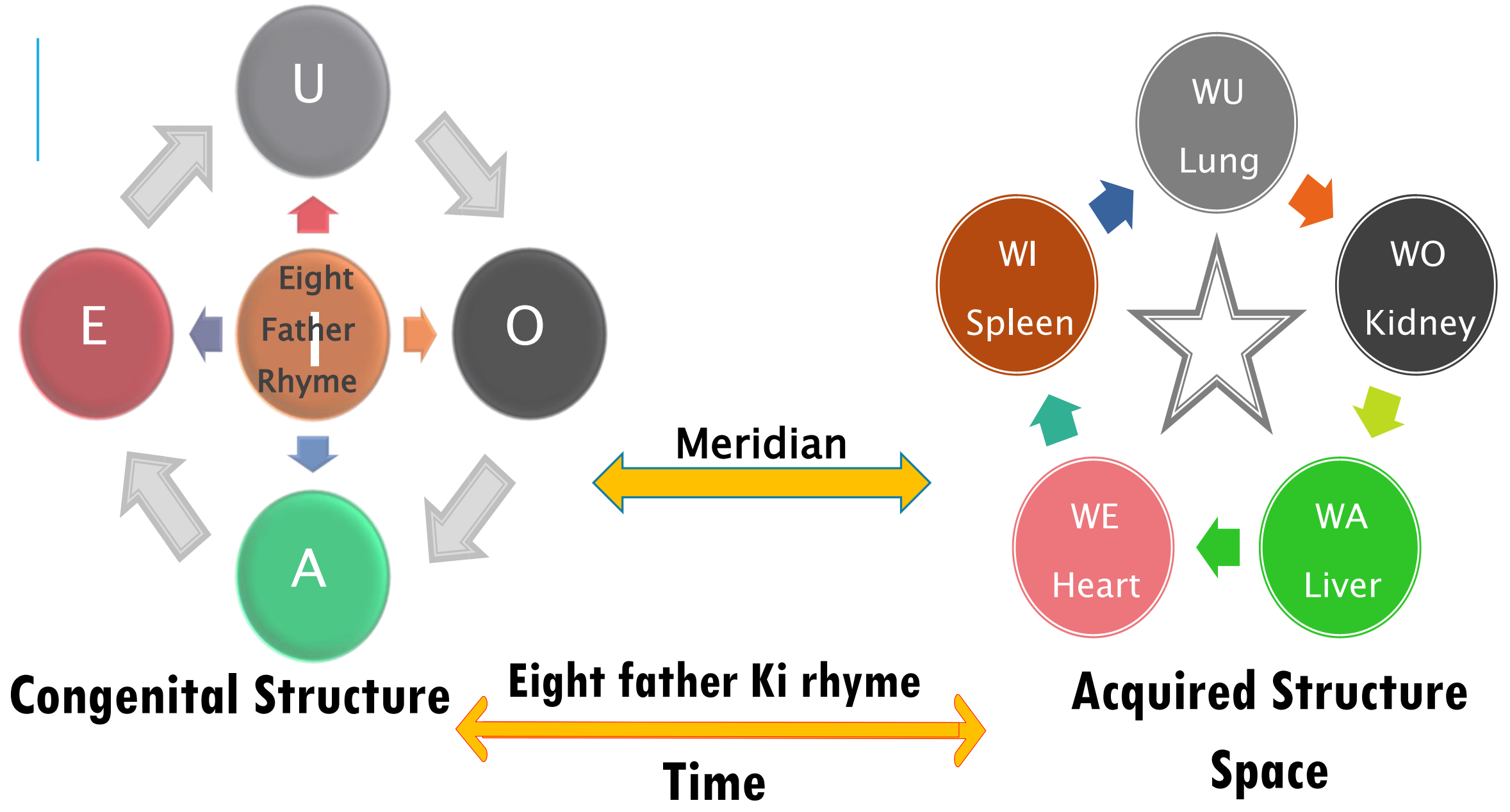

* HARI SHIMPO

POSTURE AND
KI-BREATHE
(EIGHT FATHER KI RHYME)

U 奇魂 くし、智。神からのメッセージ
O 和魂 にぎ、親。調和とバランス
A 幸魂 さち、愛。幸を感じる
E 荒魂 あら勇。願いを叶え物事を具現化
I 直霊 なおひ、高次の自分、無意識

U - **Metal**: Desire on five senses, Industry, Economy

O - **Water**: Empirical wisdom, Studies, Science

A - **Wood** : Emotion/Love/Space, Art, Religion

E - **Fire** : Practical wisdom of selection, Political Morality

I - **Earth** : Space creation Will, Activate other
four dimensions

ONZU

- U** Amatsu-Kanagi
 - A-kasatanahamayara-Wa
- O** Akatama
 - A-katamahasanayara-Wa
- A** Takara
 - A-takarahasanayama-Wa
- E** Amatsu-Futorito
 - A-takamaharanayasa-Wa
- I** Amatsu-Sugaso
 - I - any order - Wi

Subject

Objective appearance on Society

A Wood Emotion Art, Religion LR/GB **wa**

O Water Empirical knowledge Studies, Science KD/BL **wo**

U Metal Desire on five senses Industry, Economy LU/LI **wu**

E Fire Practical Wisdom of Selection Political Morality HT/SI **we**

I Earth Space Creation Will
Activate 4-mother Space with Eight father rhyme SP/ST **wi**

Ki

T

K

M

H

R

N

Y

S

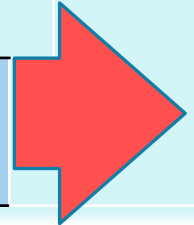

天津 太祝詞 AMATSU-FUTONORITO ONZU

	T	K	M	H	R	N	Y	S	
A	Ta	Ka	Ma	Ha	Ra	Na	Ya	Sa	wa
I	Ti	Ki	Mi	Hi	Ri	Ni	Yi	Si	wi
E	Te	Ke	Me	He	Re	Ne	Ye	Se	we
O	To	Ko	Mo	Ho	Ro	No	Yo	So	wo
U	Tu	Ku	Mu	Hu	Ru	Nu	Yu	Su	wu

The Flow of the KI 

YATA NO KAGAMI

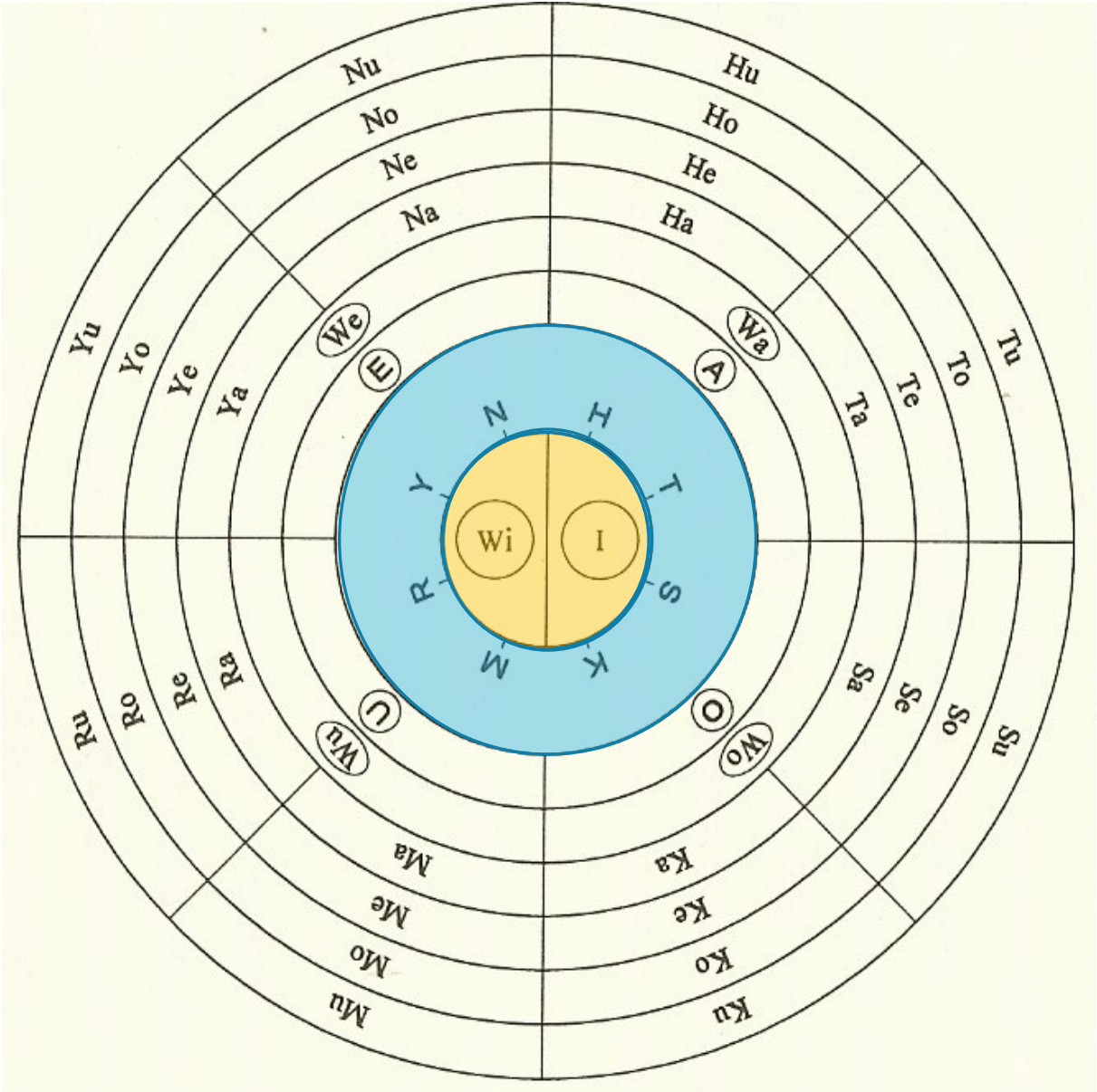

THE PILLAR OF THE HEART

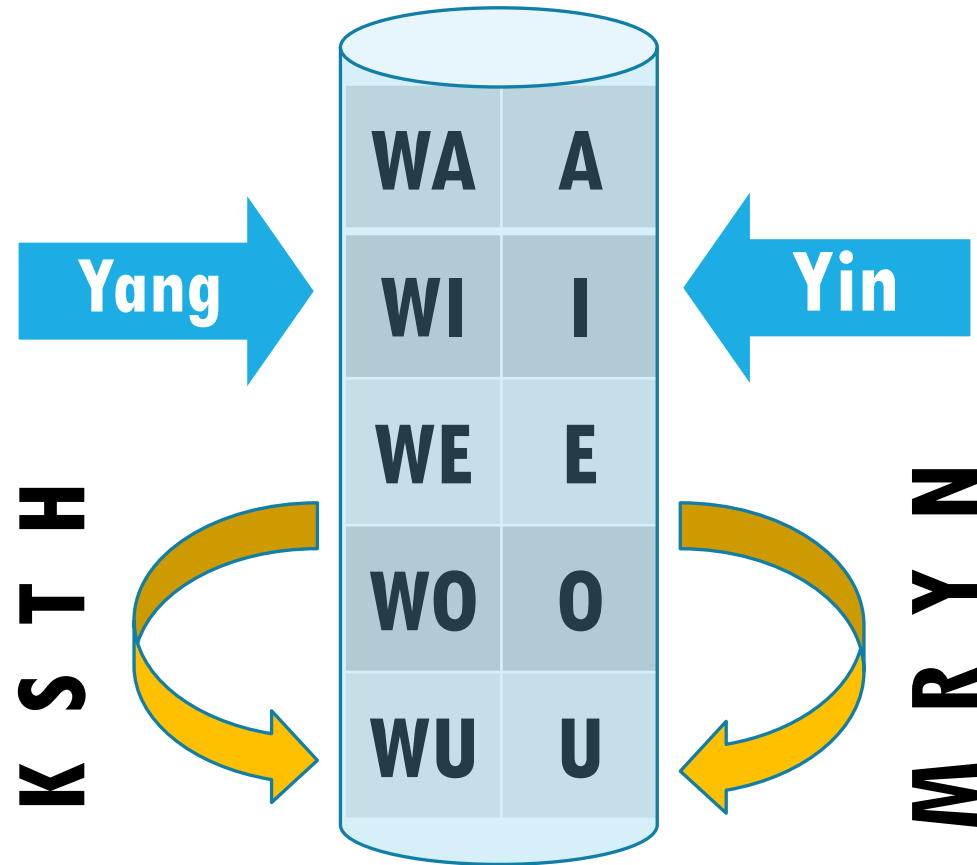

HARI ROOT TREATMENTS

SHO/ DX. AND POINTS

Step 1, 2 and 3.

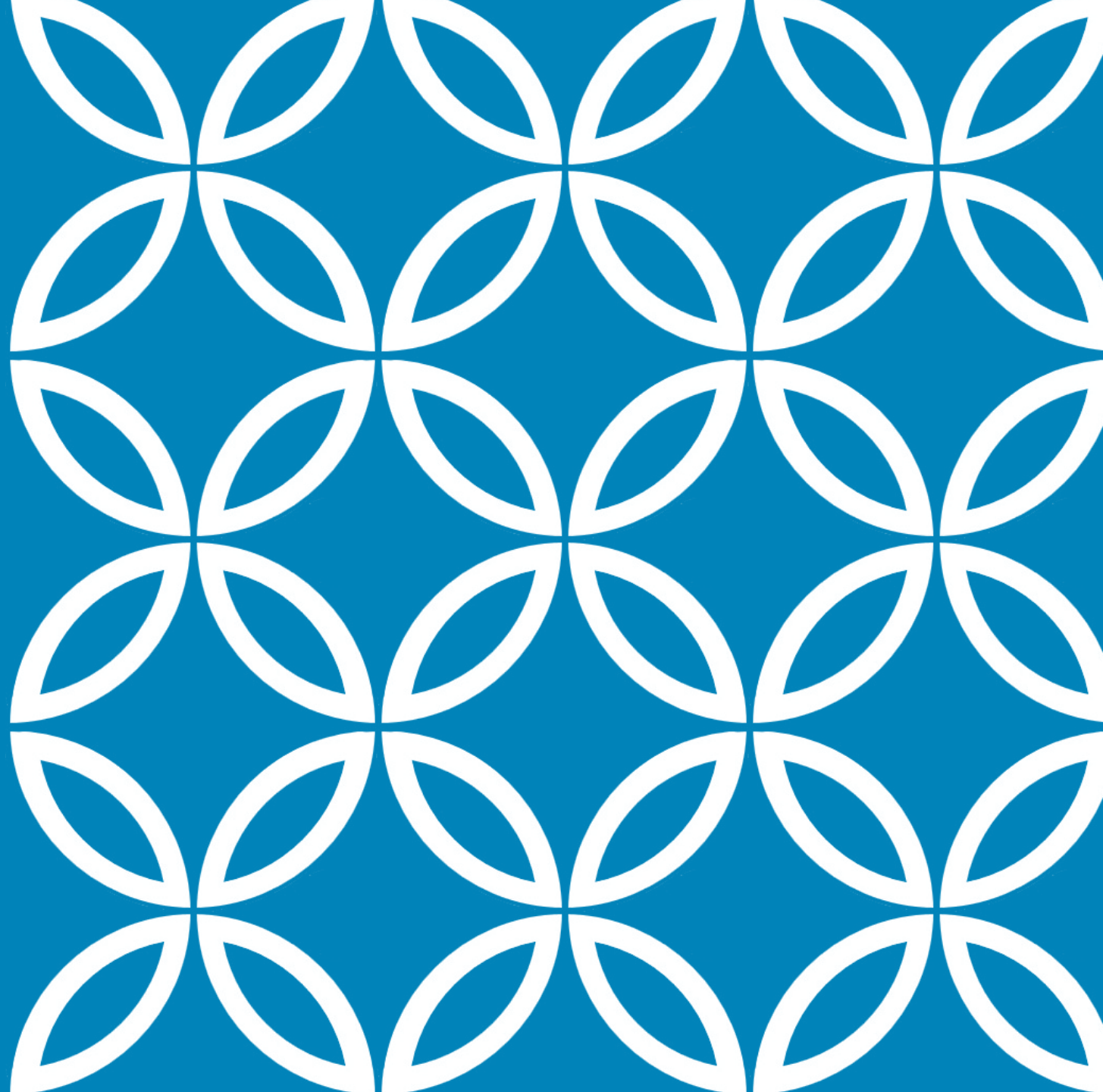

* **HARI**
TX. STEPS

ROOT TX.
STEPS 1

2

3

- **Stp 1. Primary SHO,**
Five-dimensional Spiritual Pattern
Intuitive dx. (A-Ha) and Six-Comparative Pulse dx.
w/Principles of tx.,
- **Stp 2. Secondary SHO,**
Pathological (Physical Body) Pattern
Effects from Meimon (Life of gate) with Jaki
effects as excess to body. Pulse (Quality dx.)
- **Stp 3. Yang meridians**

□. TX. SIDE

AND

MAIN TX. POINTS

□ WITH KISHIN DX.

❖ Deficiency, tonify source pt. on same side as pulse or/and Kishin dx.

❖ Excess, disperse on same side that effected from Jaki.

use Luo point, if symptoms is severe, can be used Xi-Cleft pts.

**□. HOW TO
FIND**

**DEFICIENT
POINT**

- ❖ The deficient point is sticky, depressed or weak.
- ❖ Those area with no energy flow appears dark.

□. HOW TO
FIND

EXCESS POINT
AND
JAKE INVASION

- ❖ The point that was affected from Jaki is unsmooth, convexed or hard, rough.
- ❖ Those area with energy flow appears as darkness and volcano/tornado pattern.

HARI TREATMENT

“ HARI SHIMPO ”

Nenshin (1)(2)
with Kototama

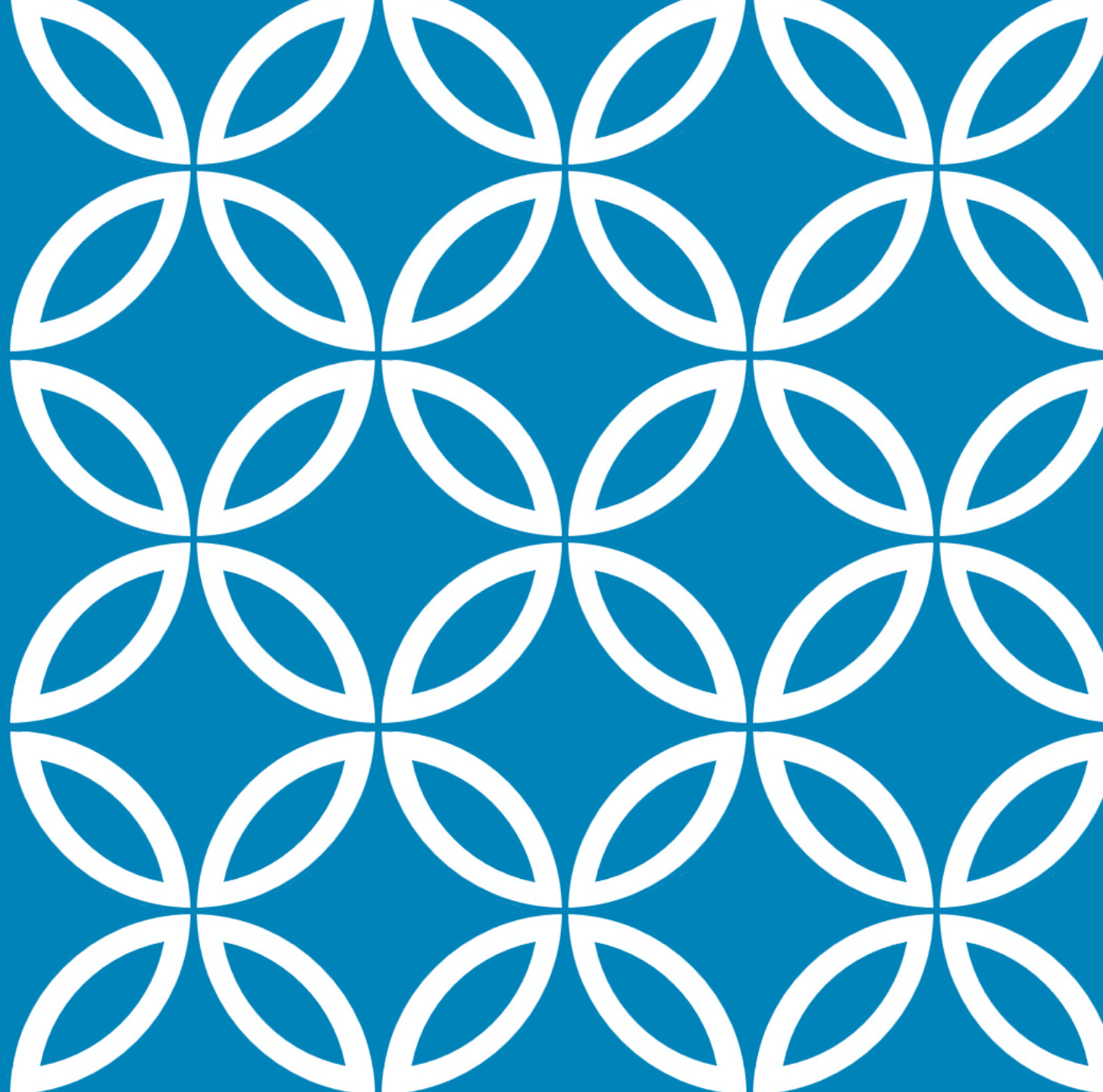

HARI SHIMPO

KEY POINTS

Kototama Hari Practice

1. Conscious-Intension:
 - Power of Words and its effects
2. Ki-Breath and Body Posture
3. Gassho-Gyoho
4. What is a Kundalini? and Its effects.
5. Nenshin (1) (2)



HARI SHIMPO

KEY POINTS

Kototama Hari Practice

- 1. Hari needling**
 - Shape, Positioning of Body Posture Usage
 - Oshide/ L-hand
 - Sashide/R-hand
- 2. Timing for going and removal with lightment.**

* **HARI
SHIMPO**

POSTURE AND
KI-BREATHE
(AI-GASSHO GYOHÔ)

U - upward

O - down

A - front

E - back

I - Center

One **S**pirit

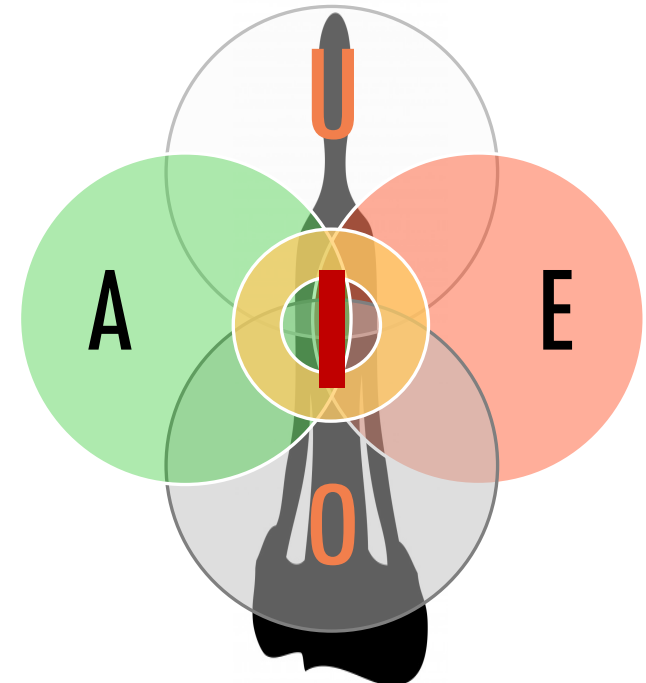

Four **S**ouls

Middle-Tanden (Between **CV18** and **GV11**)

HARI SHIMPO

AI-GASSHO GYOHÔ

(**AI** 愛-LOVE) = “SPACE”

AI IS THE LOCUS OF FEELINGS
OF SPACE WILL (**I**).
IT IS PASSION, 愛-LOVE.

A IS “WOOD” ELEMENT AS
BLOOD WITH SPACE WILL (**I**) IN
BODY .

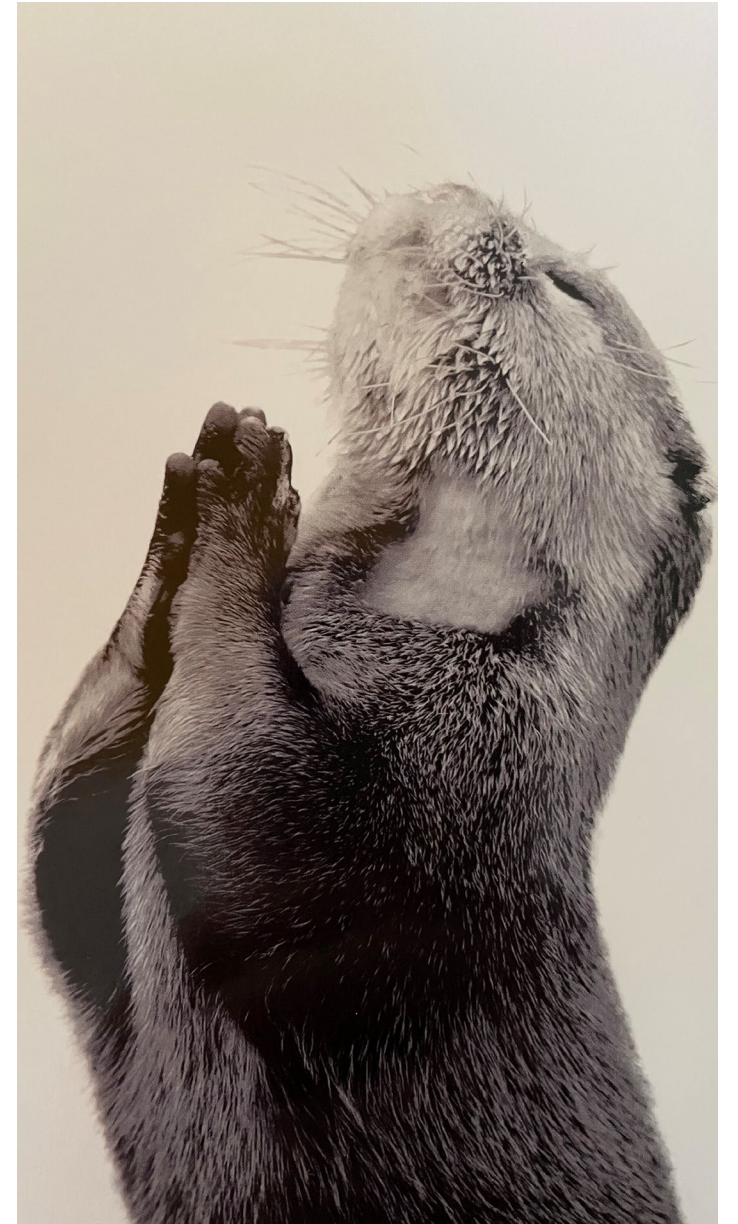

HARI SHIMPO

KI-BREATHE WITH KUNDALINI

AI-GASSHO GYOHÔ

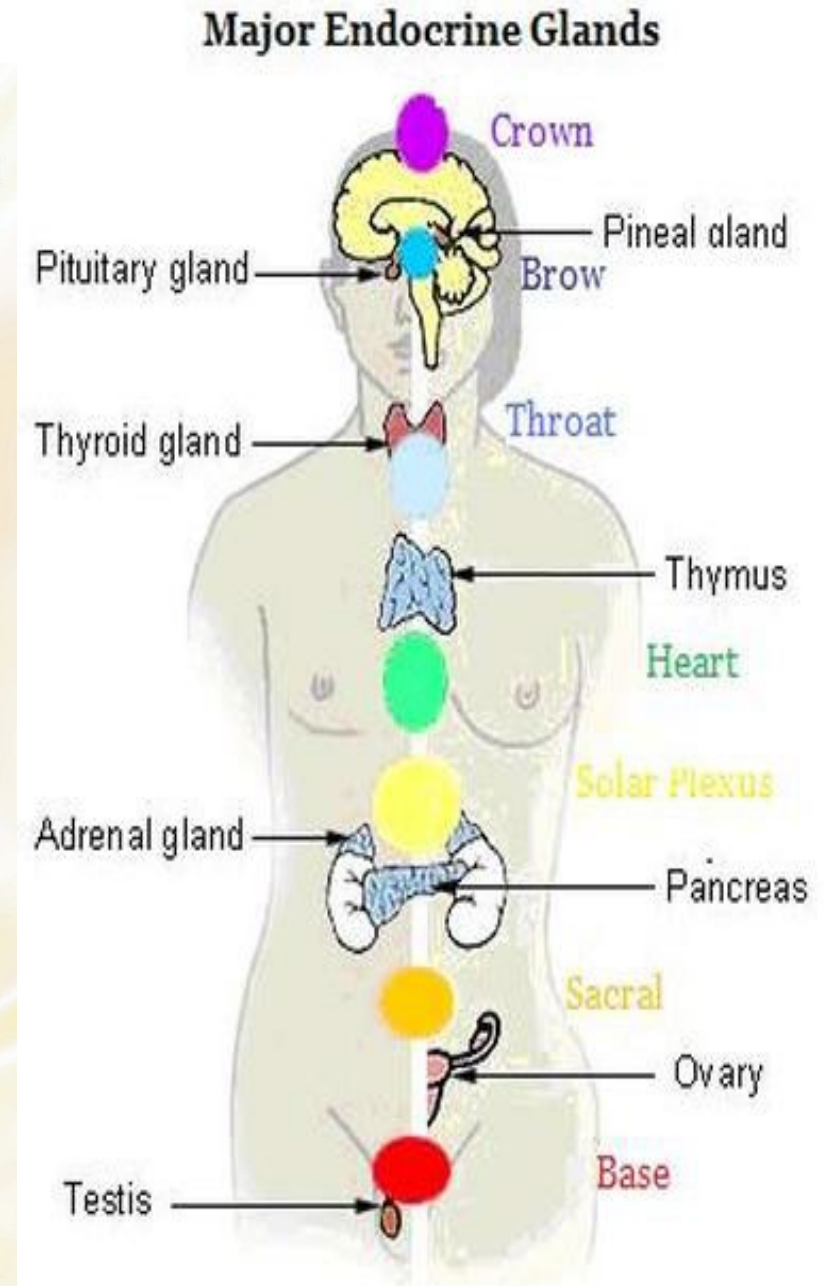
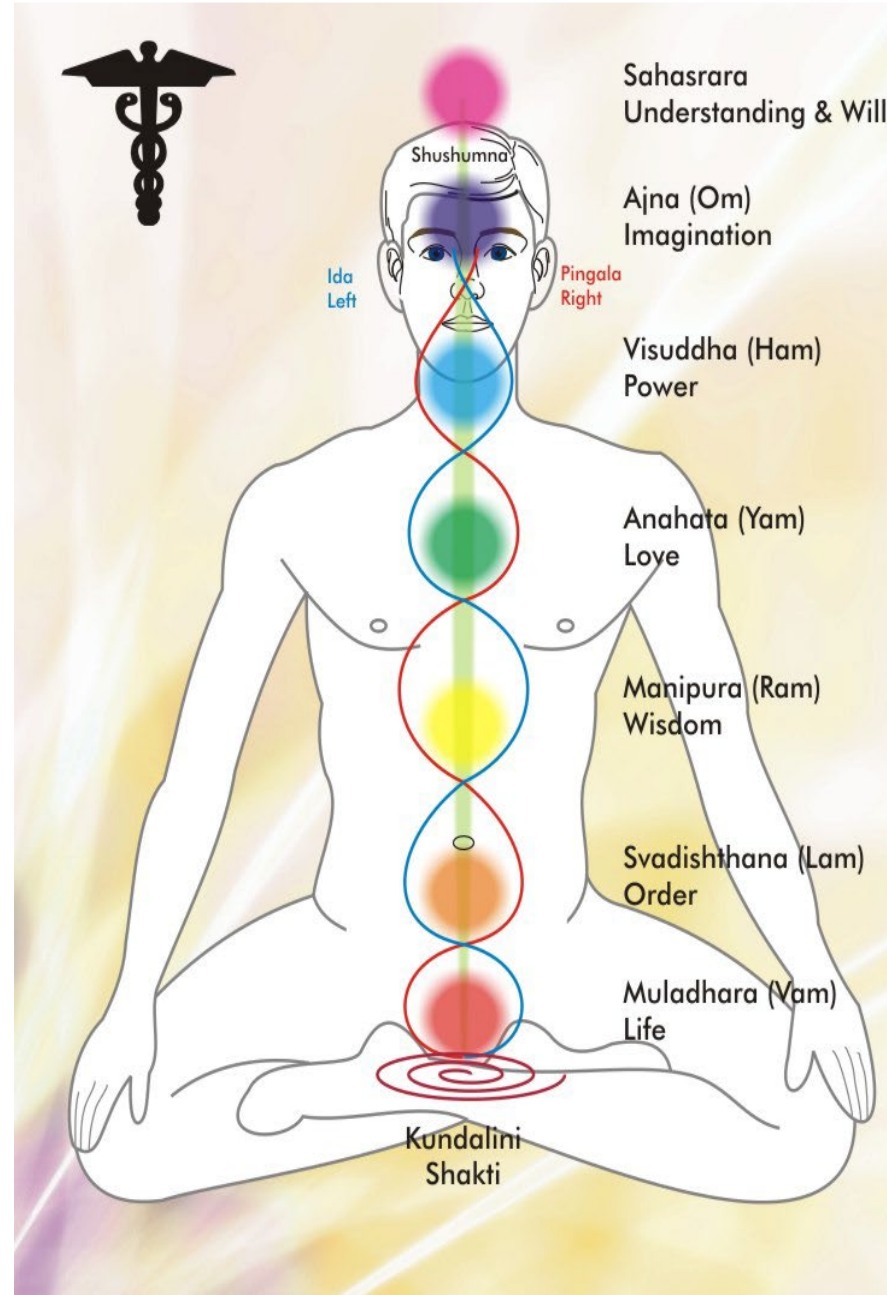

**HARI
SHIMPO
TONIFICATION**

❖ **Ho-ho**

Creation of the Light

Effect of the tx. is with the practice on

a- **Quality,**

b- **Quantity of the Ki and**

c- **Points, Oshide-Sashide**

and Nen-Shin (1) Methods.

TONIFICATION WITH $\sqrt{-}$ I

$\sqrt{-}$ i

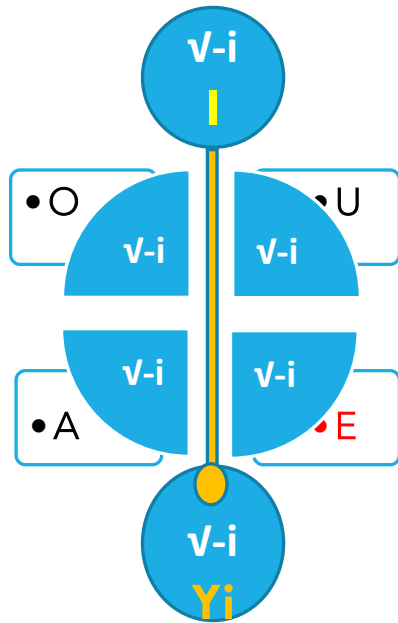

Step (1)

Pressure from center of your finger

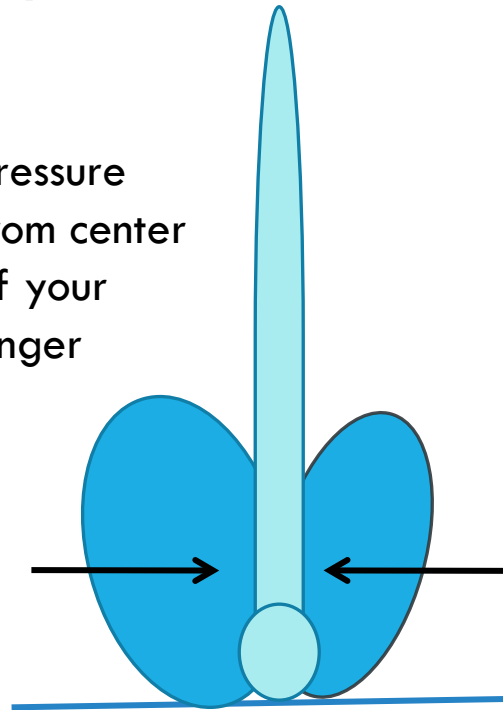

Beginning of Tonification

Step(2)

Pressure from upper side of your finger

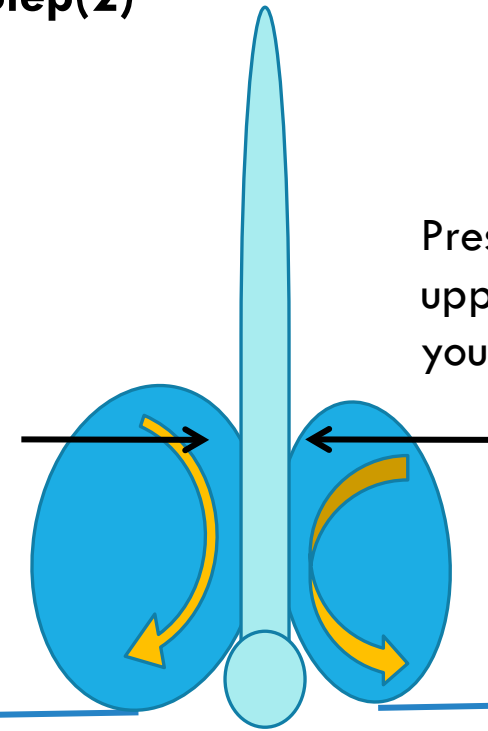

and removal

**HARI
SHIMPO**

SHA

**DISPERSION
(MISOGI)**

❖ **SHA-ho**

Sha-ho retune the rhyme/ (Eight Father Ki Rhyme) and Time.

1. Release the attachment on the meridian that disharmonized the nature.

HARI SHIMPO

DISPERSION
TECHNIQUE

(2) SHA FOR JAKI

Two type of Excess (Jitsu)

(1) Oki-Jitsu

Natural Excess without Jaki

(2) Jaki-Jitsu

Excess, effected by Jaki.



JAKI

DISPERSION

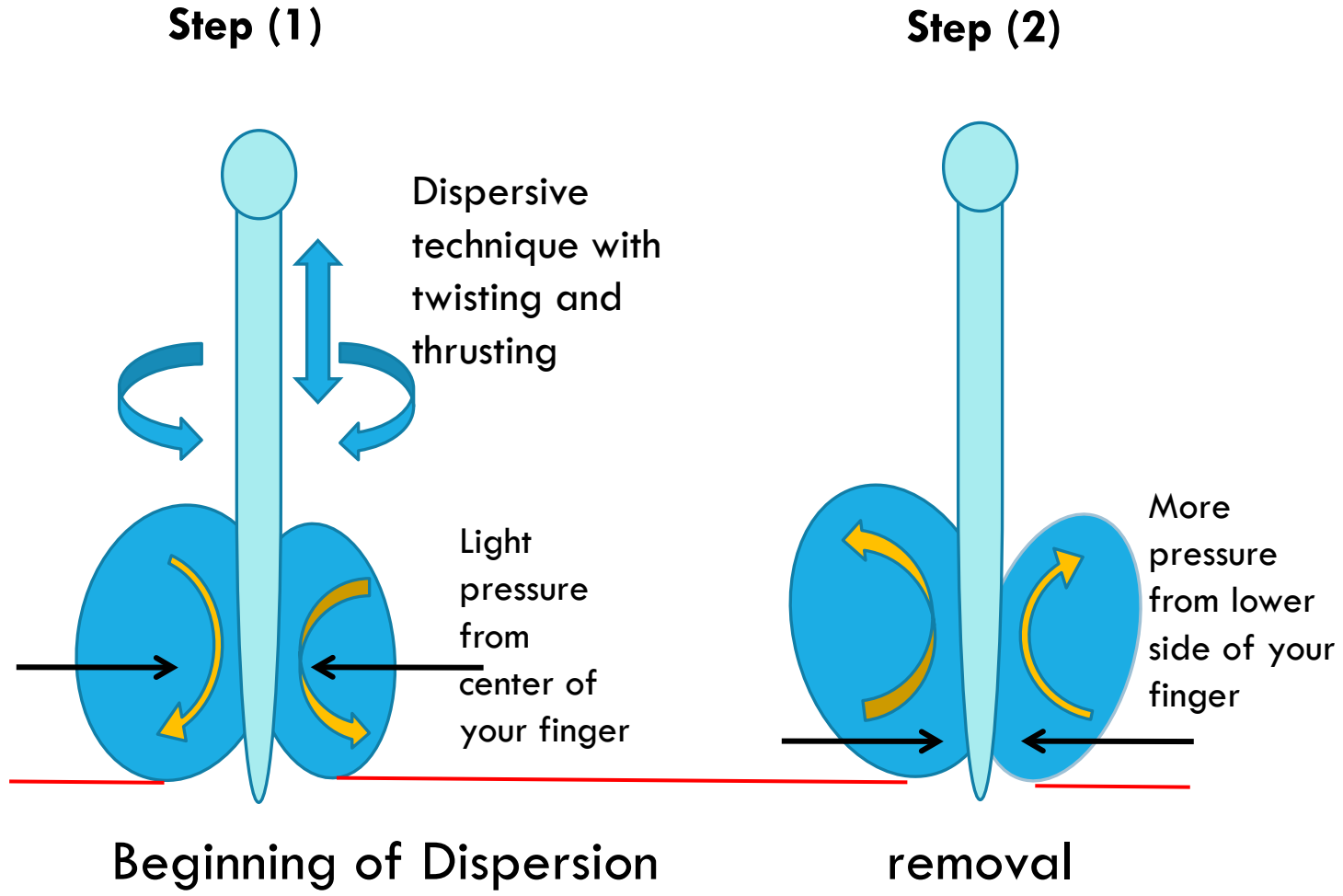
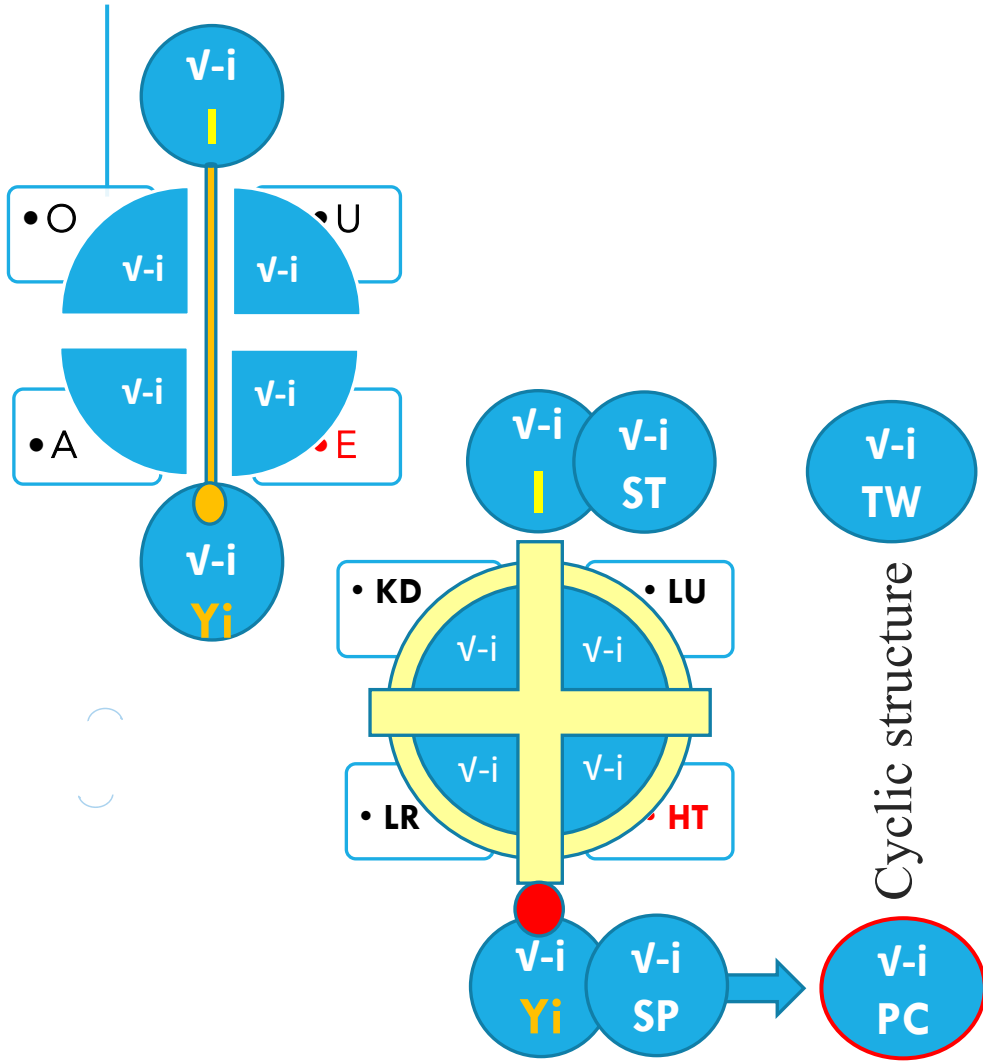

DISPERSION WITH MÖBIUS

Möbius Dispersive technique with 3-Dimensional twisting and thrusting

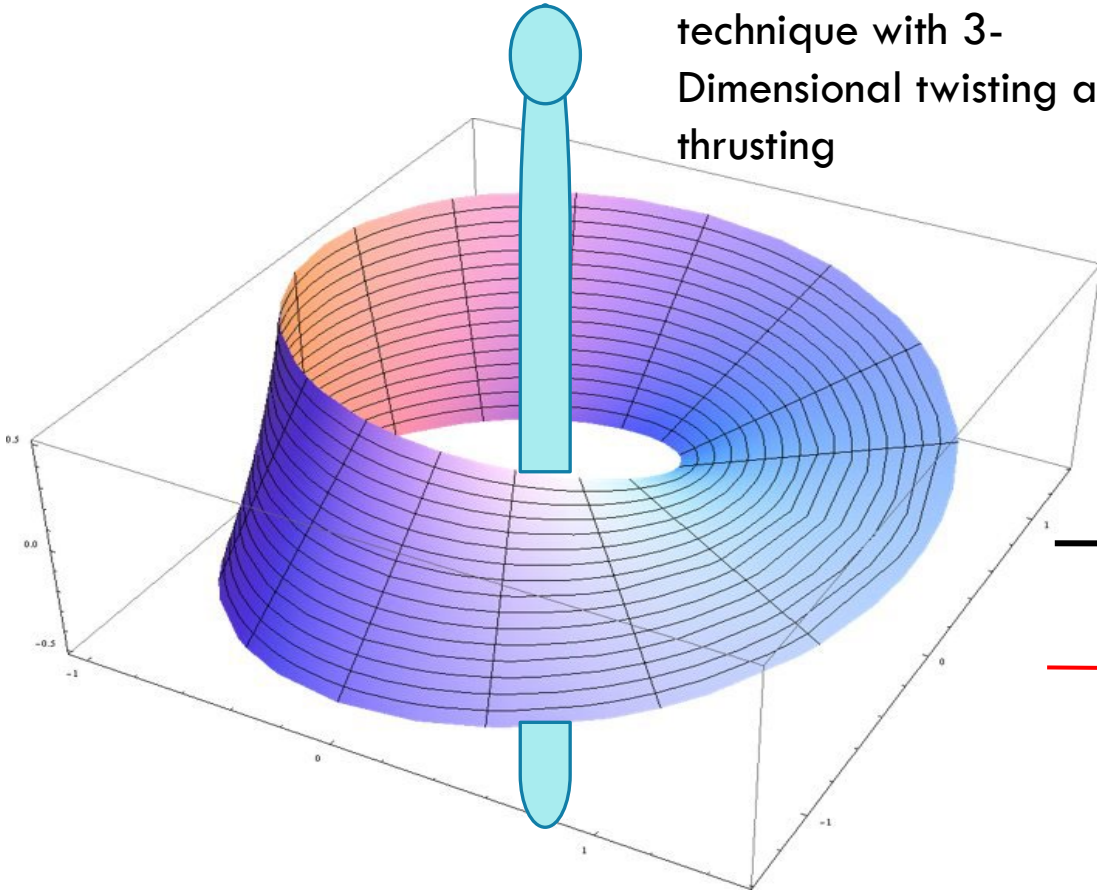

Step (1)

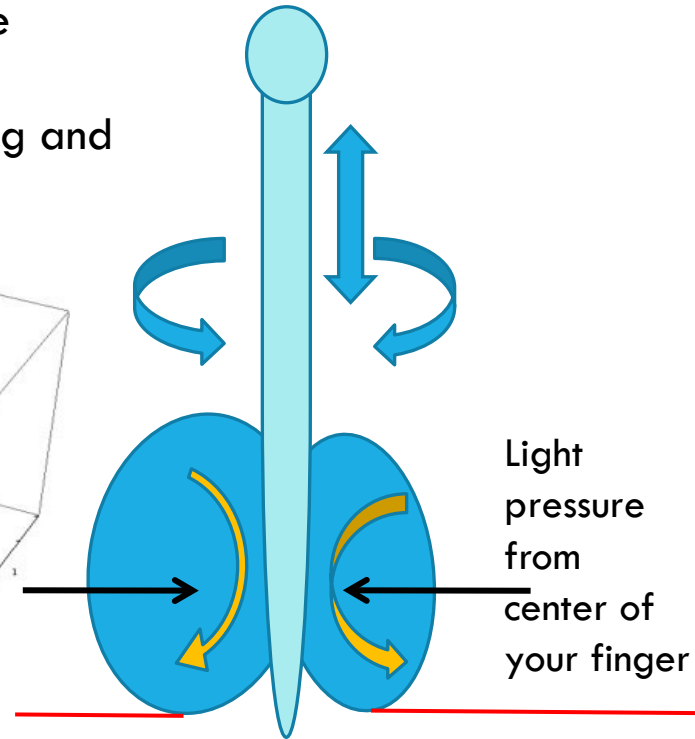

Beginning of Dispersion

Step (2)

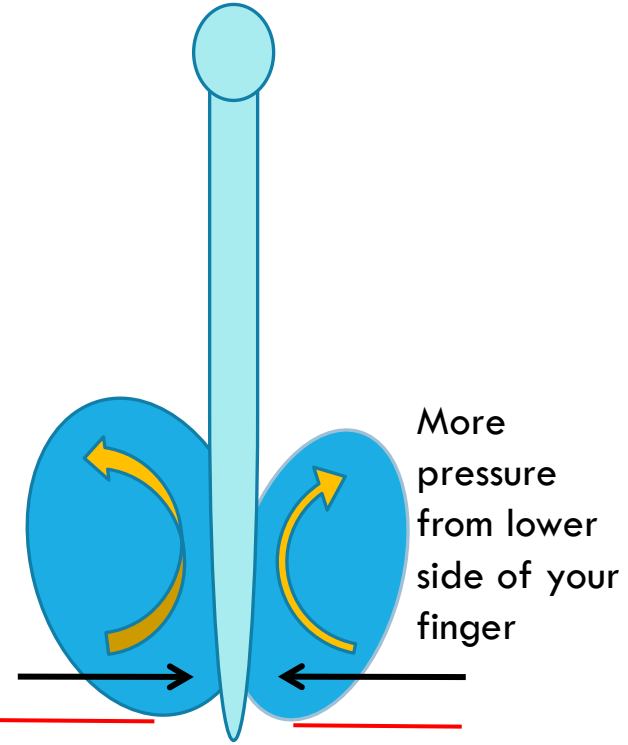

removal

HARI PULSE DIAGNOSES

Stomach Pulse and depth of the pulse position

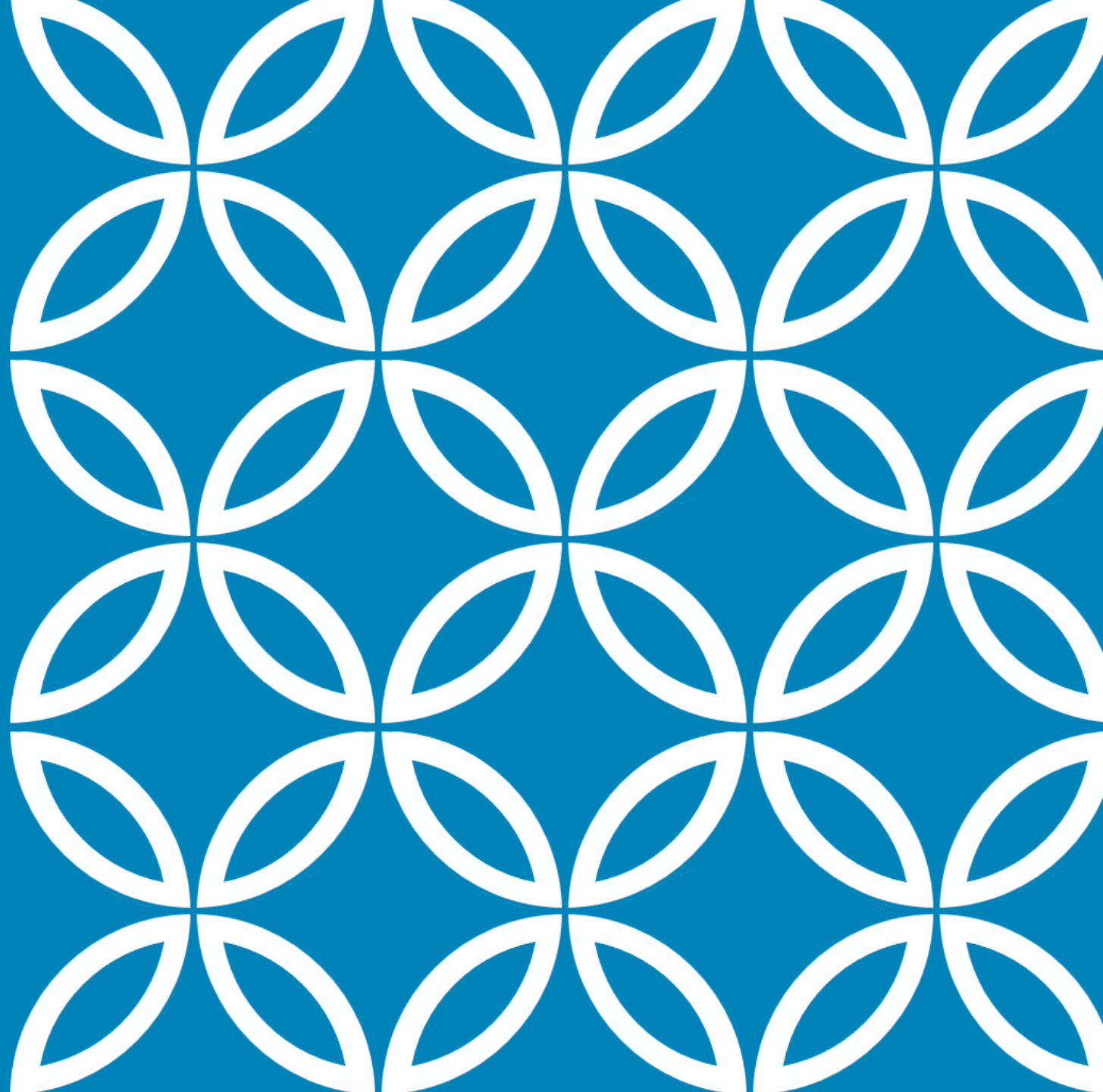

PULSE DX.

POINTS
TO
UNDERSTAND ABOUT
STOMACH
(**CALM**) PULSE QUALITY

1. ST Ki can be judged as being abundant if the pulse has enough depth (thickness) in between the superficial and deep levels.
2. ST Ki quality should feel as moderate and peaceful. * *Myakutei*

PULSE DX.

SIX COMPARATIVE PULSE Dx.

FOR PRIMARY SHO

MIDDLE PULSE

- A) Middle pulse is the line where the three fingers feel equally and clearly the pulse.
- B) It is also the place where the pulse is felt the strongest.

❖ First, Find the Middle Pulse, then

1. Compare the Yin/Yang,
2. Find deficiency/excess (Oki-jitsii)
in the 6 positions.

PULSE DX.

PULSE QUALITY Dx.

FOR SECONDARY SHO

□ Locate the abnormal pulse that is come with **Pathological** effects from **Jaki** invasion.

1. Detect the Jaki Ki in pulse that is missing the ST Ki pulse quality.
2. It shows the Hesitate pulse that caused with excess or deficient type of Jaki.

PULSE DX.

□ Use the pulse quality + sense dx.

FEEDBACK METHODS

WITH

1. PULSE QUALITY

2. 6TH - 7TH SENSE

:

1. For more than just identifying SHO/
pattern of disease.
2. It can be used as a feedback method,
assessing the effectiveness of the tx.
as it is being given.

HARI LOCAL TREATMENTS

Volcano and Sanshin
Step 0, 4 and 5.

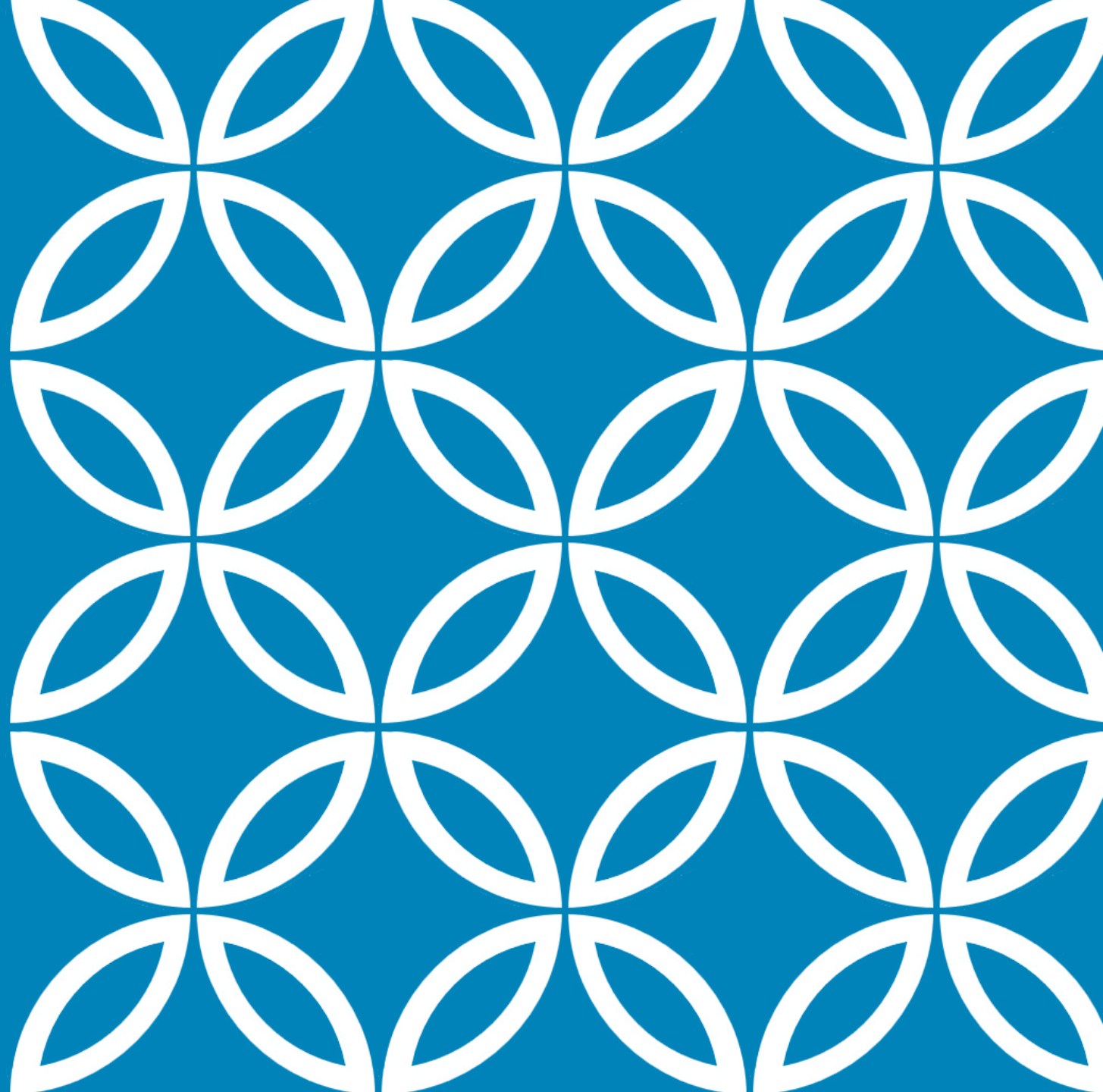

*** HARI**

**ORDER OF
LOCAL TX.**

STEP. 0

. 4

. 5

0 and 4

[A] Thoracoabdominal, Back Region and
Supplementary systems & Local points

[B] Affected Area

[C] Harmony points

5 [A] Finish needling

[B] Moxibustion

[C] Home treatment

* **HARI**
LOCAL TX.

STEP **0**, **4** AND **5**:

- A: Supplementary systems**
(EV, Shigo, Shiraku, Ketsubon/Kigai...)
- B: Volcano point tx. w/Nenshin(2)**
Sanshin tx. (Hifushin, Piano touch....)
- C: Harmony Points**
- D: Home therapy**
(Moxa, Magnet, Pressball...)

HOW TO
FIND

EXCESS POINT

- ❖ **Dispersing point (Volcano/Tornado)**
has a resistance (losing flexibility).
 - Usually feels drier and tighter like a wall.

WHAT IS
VOLCANO PT.

1) Volcano point tx.: w/Nenshin (2)

2) Sanshin tx.

and Hifushin, Piano touch

SANSHIN TX.

Scattering Needle (San-Shin)

JAKI EFFECTS, PROGRESSION OF THE JAKI INVASION

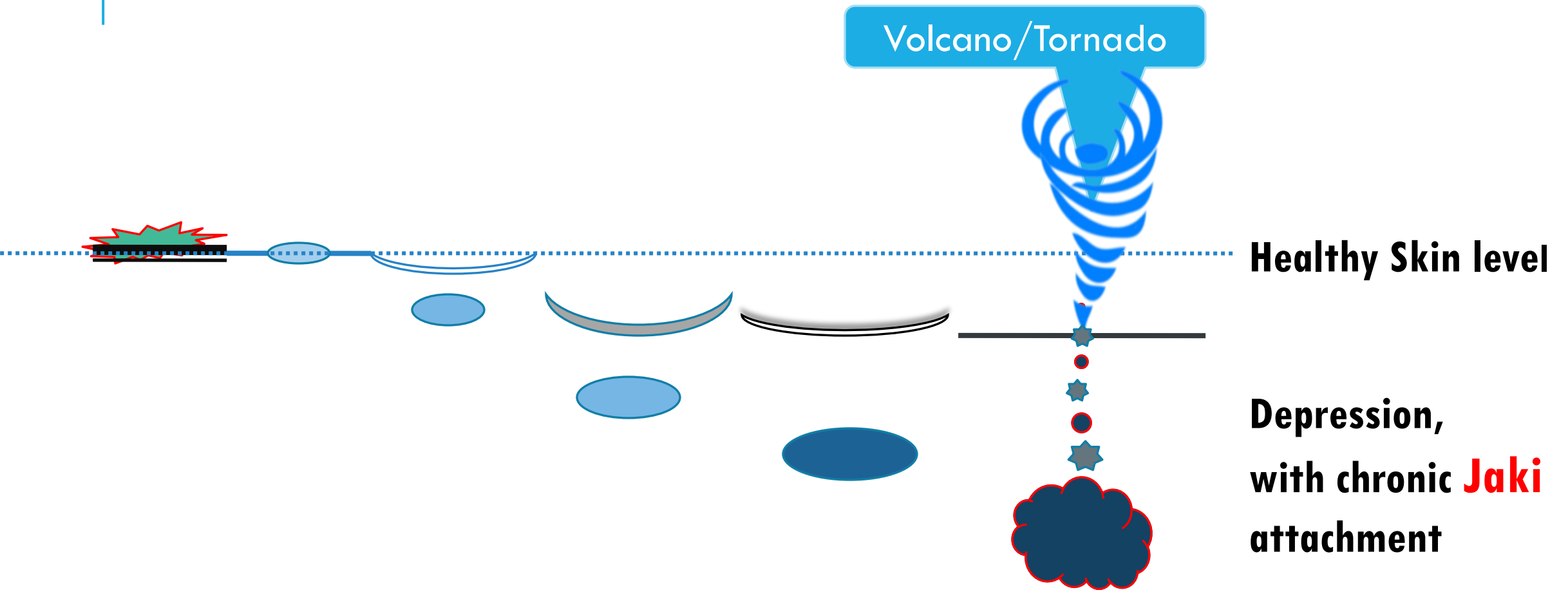

* **LOCAL TX.**

W/VOLCANO TX.

STEPS: 0. 4. 5.

Volcano, live-point

has a kind of connection to **Jaki**.

Under the point-surface, it likes an old thread and induration.

It helped by three types of tx. methods corresponding to their skin, old thread conditions.

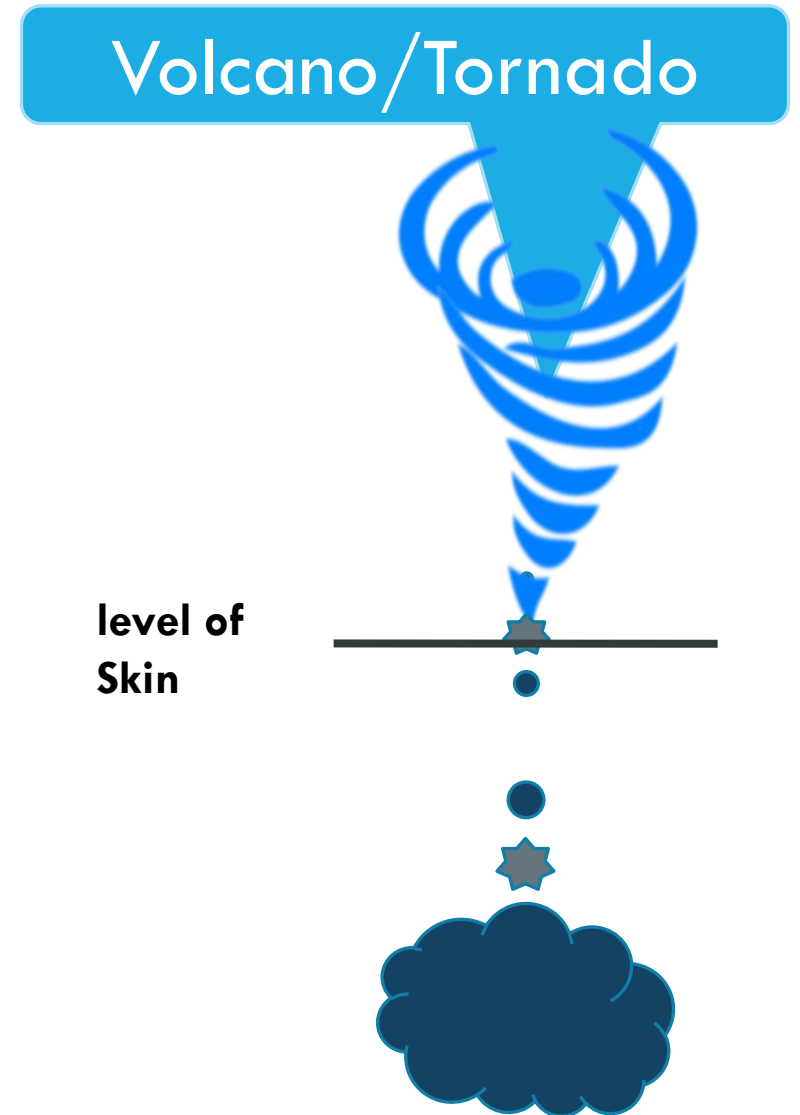

live-Volcano point with Jaki

* LOCAL TX.

VOLCANO TX.

STEPS: 0. 4. 5.

	Level of Water	Surface	Thickness of the skin
(1) Sanryo-Shin	Dry	Convex	Thick, hard, rough
(2) Go-Shin	Med	-level	or mix
(3) Chokusetsu -Kyu	Dampness wet	Concaved depressed soft, flaccid	Thin, with water retention