

HARI STYLE OF ACUPUNCTURE

IPSUM ESSE

Takayuki Koei Kuwahara Lic. Ac.
President of The Hari Society

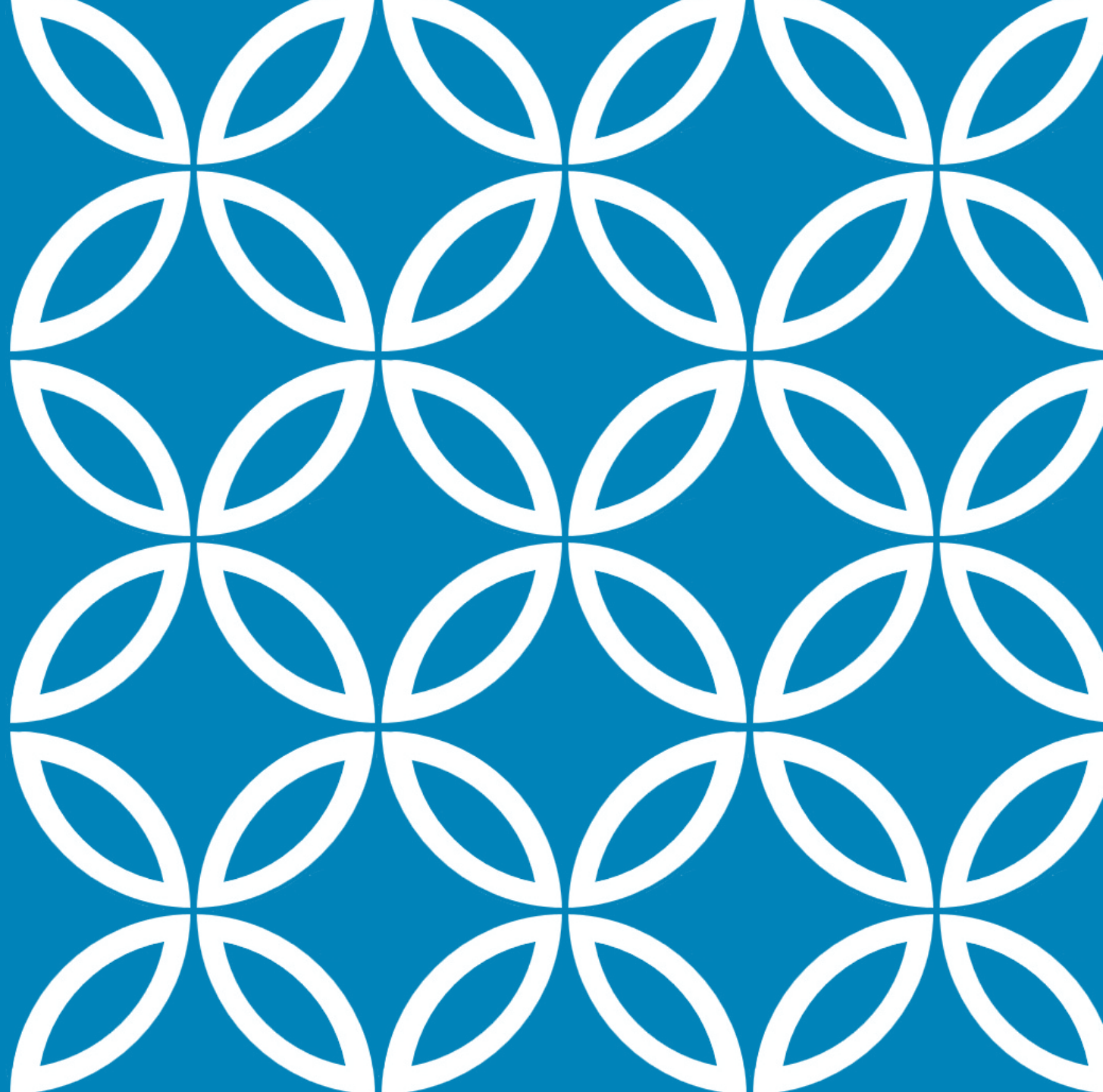

* **HARI**
DEFINITION
(1)

HARI is known as

Traditional Japanese Medicine based on pulse dx. and Kami.

It involves a clinical reading called **SHŌ/AKASHI**. Treatment is effected with **Ho** and **Sha** techniques using **hari, okyū** with Kami.

(**AKASHI**/pattern of imbalance in the five phases/One sprits & Four souls and its tx. order).

Meridians points serve as loci for both diagnosis and treatment.

* HARI

DEFINITION

(2)

(1) PRIMARY
SHO

(2) SECONDARY
SHO

HARI consists of two steps of SHO

(1) is on Space Will $\sqrt{(-i)}$

(One spirit \Rightarrow 4 Souls)

(2) is on Pathological effects in body
w/ Minmen and the Ja-Ki.

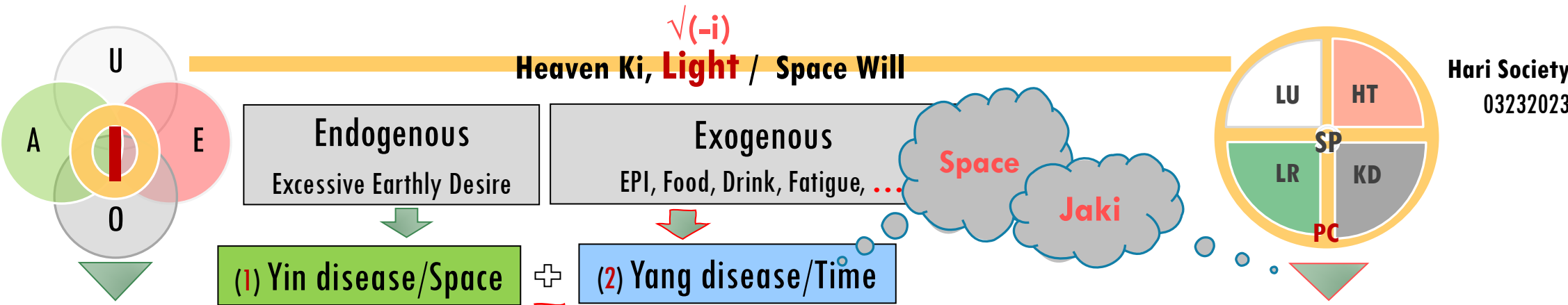

Ōki Jitsu → Fond of Life

Jaki-Jitsu → Tough Lifestyle

Constitutional Factor / 4 Souls < I Sprit | **Process of Creation** | Pathological Deficient & Excess | **Effects from Jaki**

| Mother Sounds | (1) Primary SHO | Essential Ki (4 Souls) Def. & Excess (Ōki-Jitsu) in Generating Cycle | Eight Father Rhyme Meridian | | Pathological process with Def. & Excess type Jaki-Jitsu on yang M. & Controlling Cycle | (2) Secondary SHO | Generation of Deficiency, Excess | Deficiency or Excess of Ki, Blood, Fluid |
|---------------|-----------------|--|-----------------------------|-------------------------------|--|-------------------------------|--|---|
| U | LU def. | | LU LI | KI (Space will), Blood, Fluid | | Ki | Occurrence of cold or heat symptomology due to deficiency or excess of HT and PC | Pressure Pain Resistance Cold, Heat Indurations Depressions Protuberances Dampness, Dryness |
| O | KD def. | | KD BL | | | Fluid | | |
| A | LR def. | | LR GB | | | Blood | | |
| E | HT.PC def. | | HT SI | | | Fire/Heat-Cold | | |
| I | SP def. | | SP ST | | | Ki (Space will), Blood, Fluid | | |
| | | PC TW | | | | Symptoms | | |

Flow Chart: Hari w/ EV + Shigo 03232023

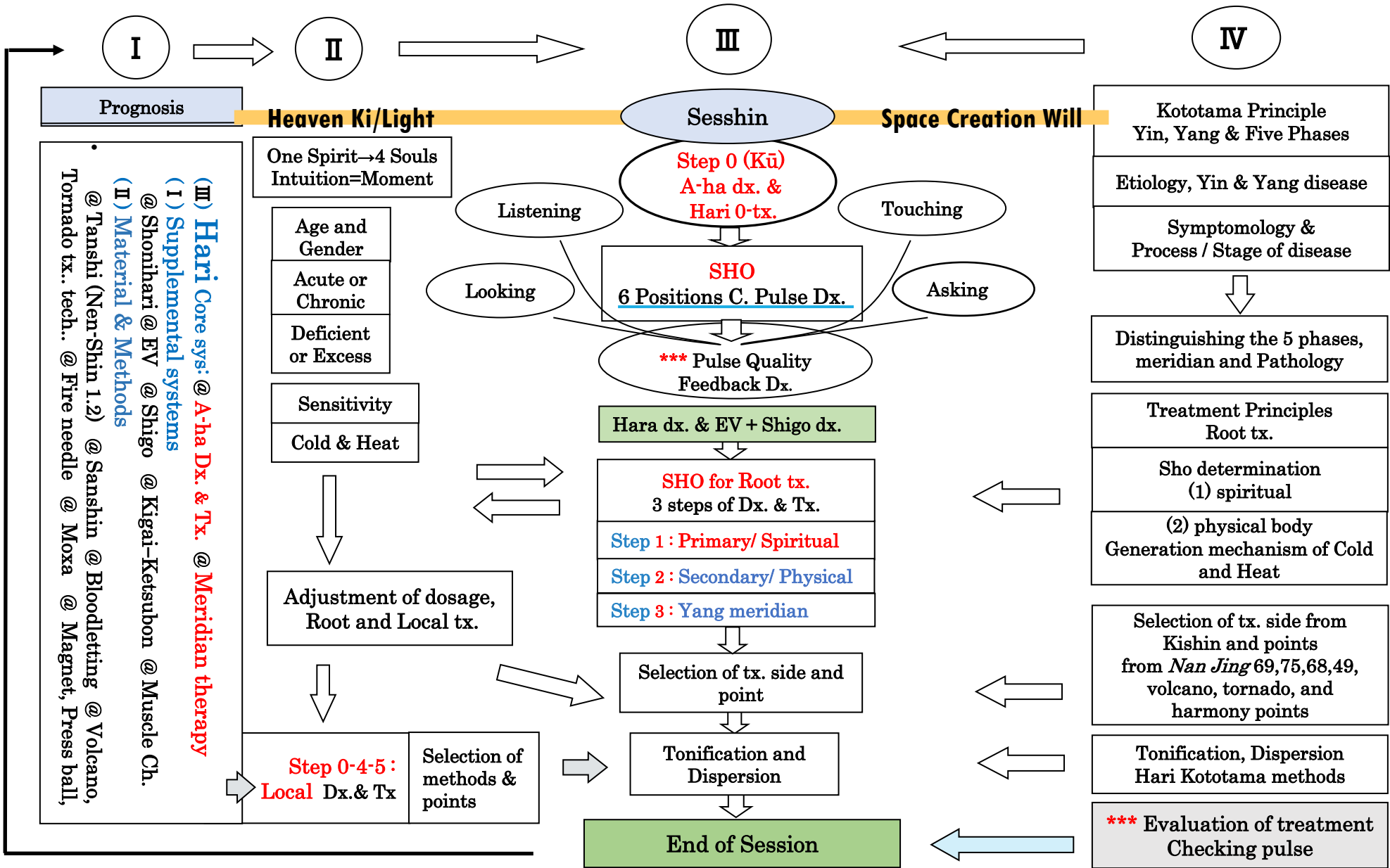

$\sqrt{-i}$

IPSUM ESSE

**HARI
A THING THAT IS
IMPORTANT.**

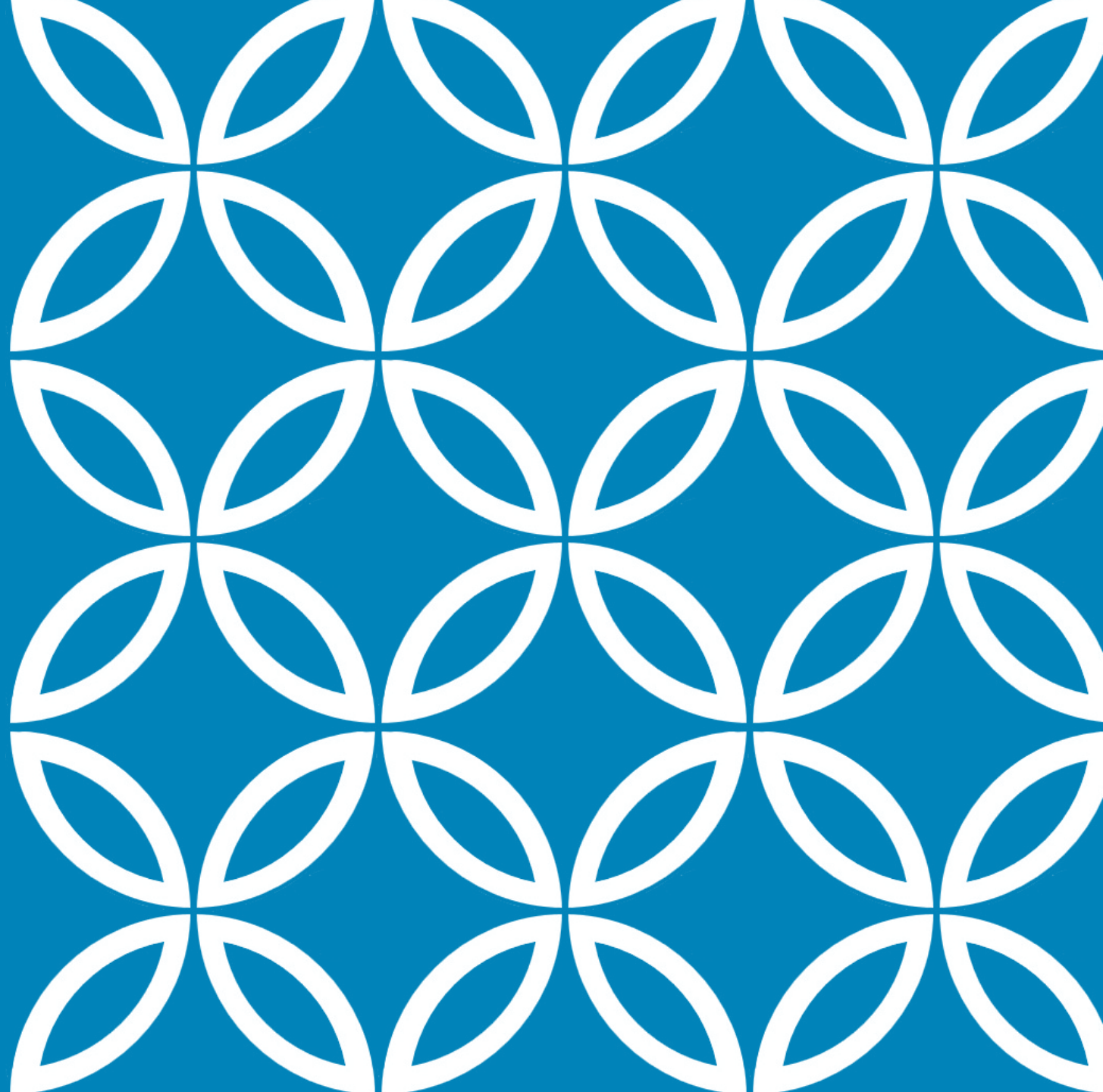

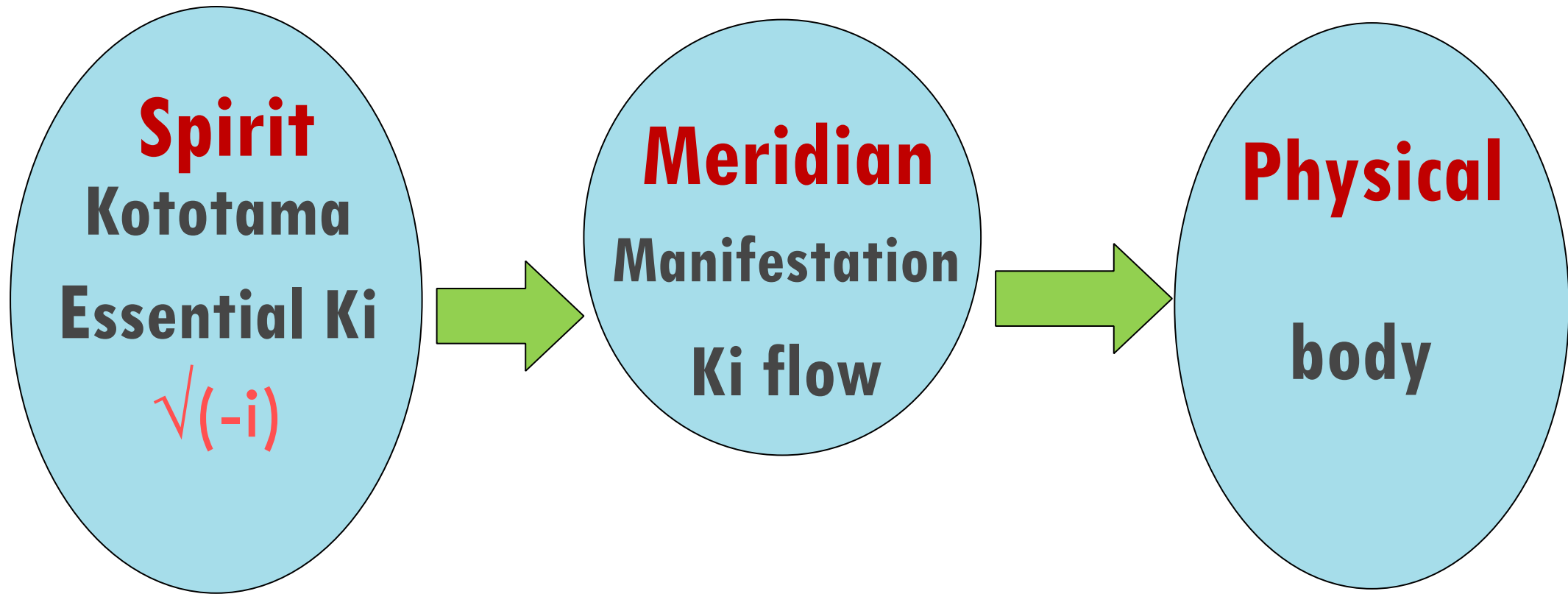

Universe of congenital structure

Acquired Structure

(A) ∞ ∞ ∞ ∞ (Eight Father Ki Rhyme) ∞ ∞ ∞ ∞ **(WA)**

***HARI**

Spirit √(-i) (ipsum esse)

ONE Spirit

⇒ Four Souls “Character w/Senses, Mind”

**THREE
CORNERSTONES
OF HARI
PRACTICE**

Meridian: Time

Ki (as “Breath”) flow/process/history of creation
between the Universe of Congenital to Acquired
Structure

Physical: Space

Pathological effects on Physical Body

Meimon (life of gate) PC-Ki: and TW

* HARI

(1)
SPIRIT



A) **Quality:**

Keep your bright spirit ✓(-i) with Enlightenment.

(2) KI-
BREATHE



B) **Quantity:**

Ki flow/undulation in proper (Mind-Body **Posture&Use**) with
(**Tanden/Kundalini**) **breath**, Kototama Breathe of the creation

(3)
PATHOLOGICAL
&
JAKI
EFFECT ON
BODY



C) **Pts. w/*Methods:**

It based on understanding of the Pathological effect (Ki, Fluid, Blood), Meimon with Jaki.

* **HARI**
KI FEEDBACK
METHODS

- WITH
1. PULSE QUALITY
 2. 6TH - 7TH SENSE

:

1. ST Ki pulse quality dx. and Sense dx..
 - How to detect abnormal and correct Ki in pulse
2. Feedback method
 - Pulse + Sense dx. can be used as a feedback method for assessing the effectiveness of the tx. as it is being given.

HARI
TECHNIQUES :

HO
SHA

HO:

**Nenshin (1) \surd (-i) with Tonification
for Life force (Minmen Fire)**

SHA:

**Nenshin (2) w/ (*Eight Father Ki Rhyme)
Dispersion for Jaki with Möbius
Dispersive technique with 4-Dimensional
twisting and thrusting.**

PRINCIPLES OF KOTOTAMA

Ancient Five Phases

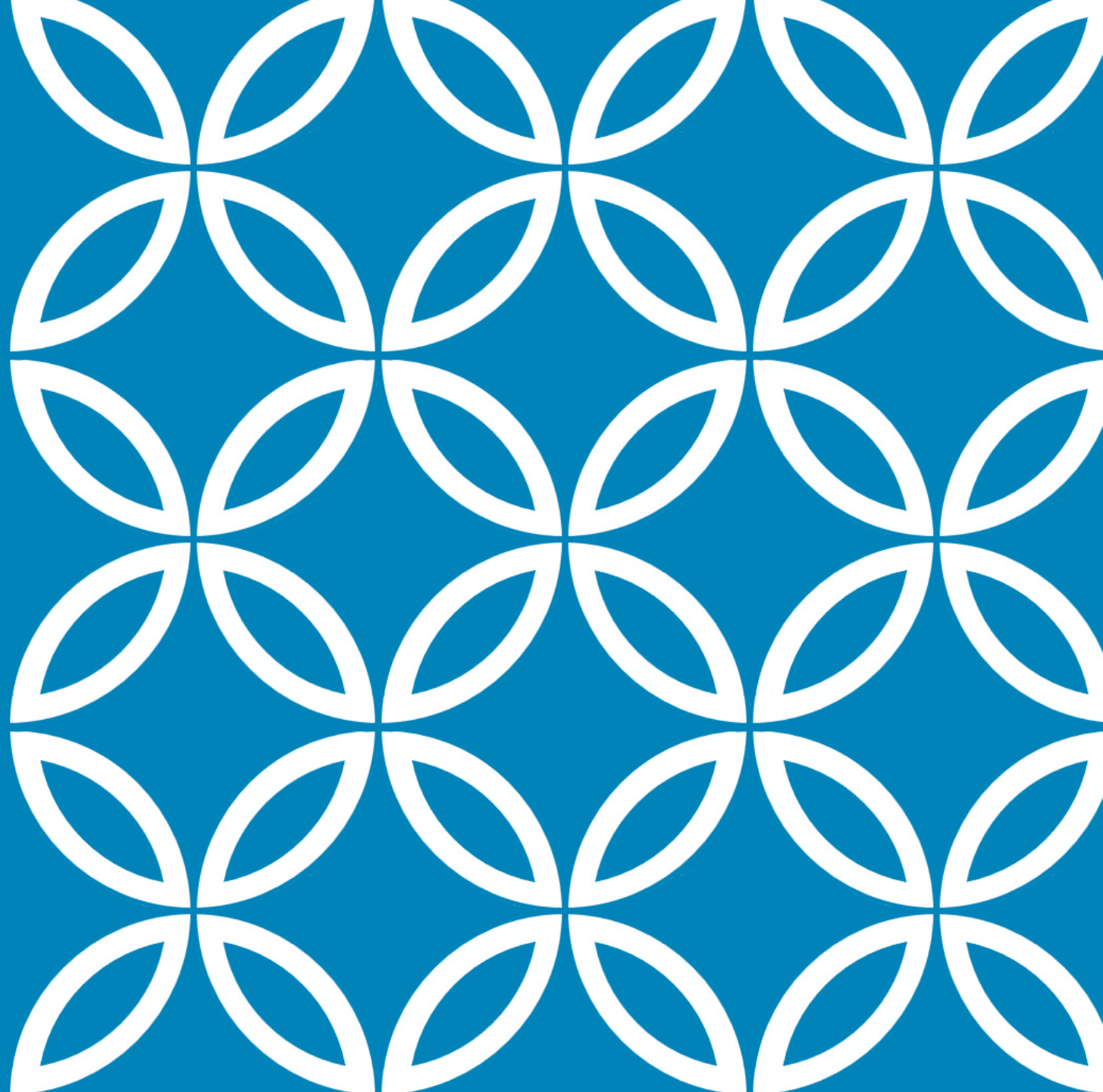



**ESSENCE
OF HARI**

KOTOTAMA

One Spirit

is

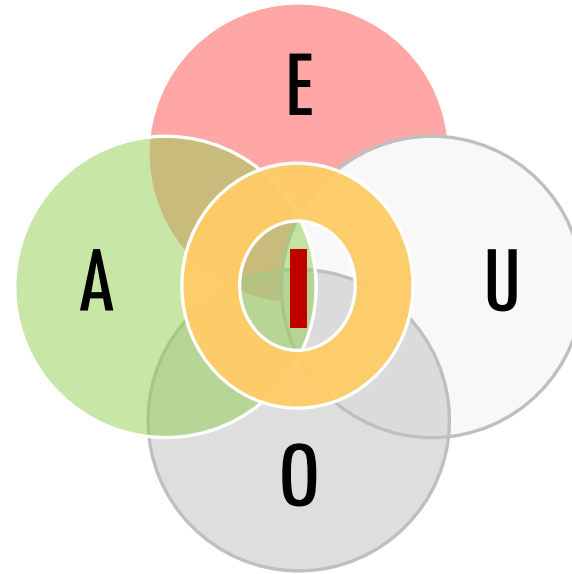

Four Souls

BASIC ORDER OF GENERATION

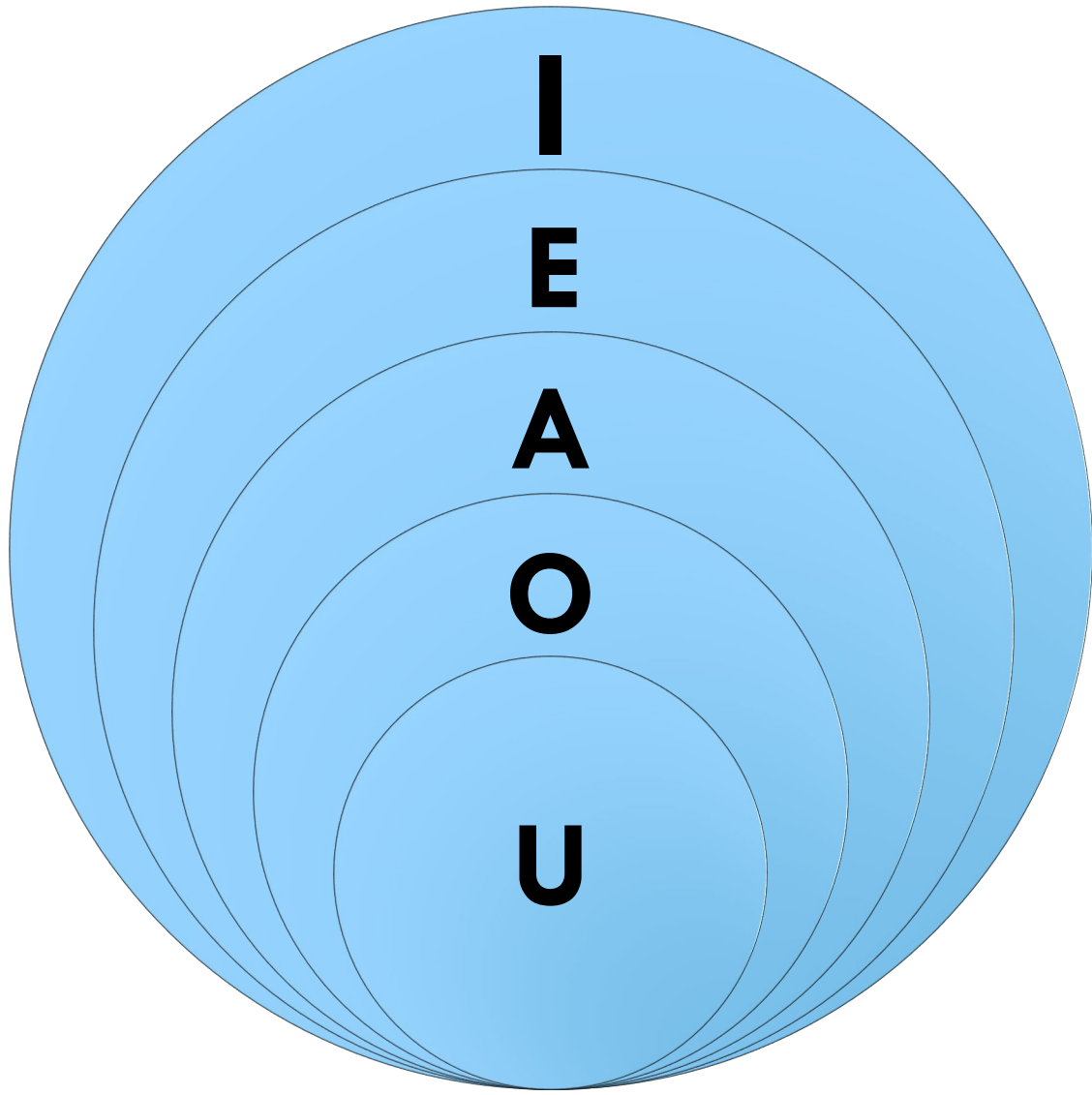

Earth

Fire

Wood

Water

Metal

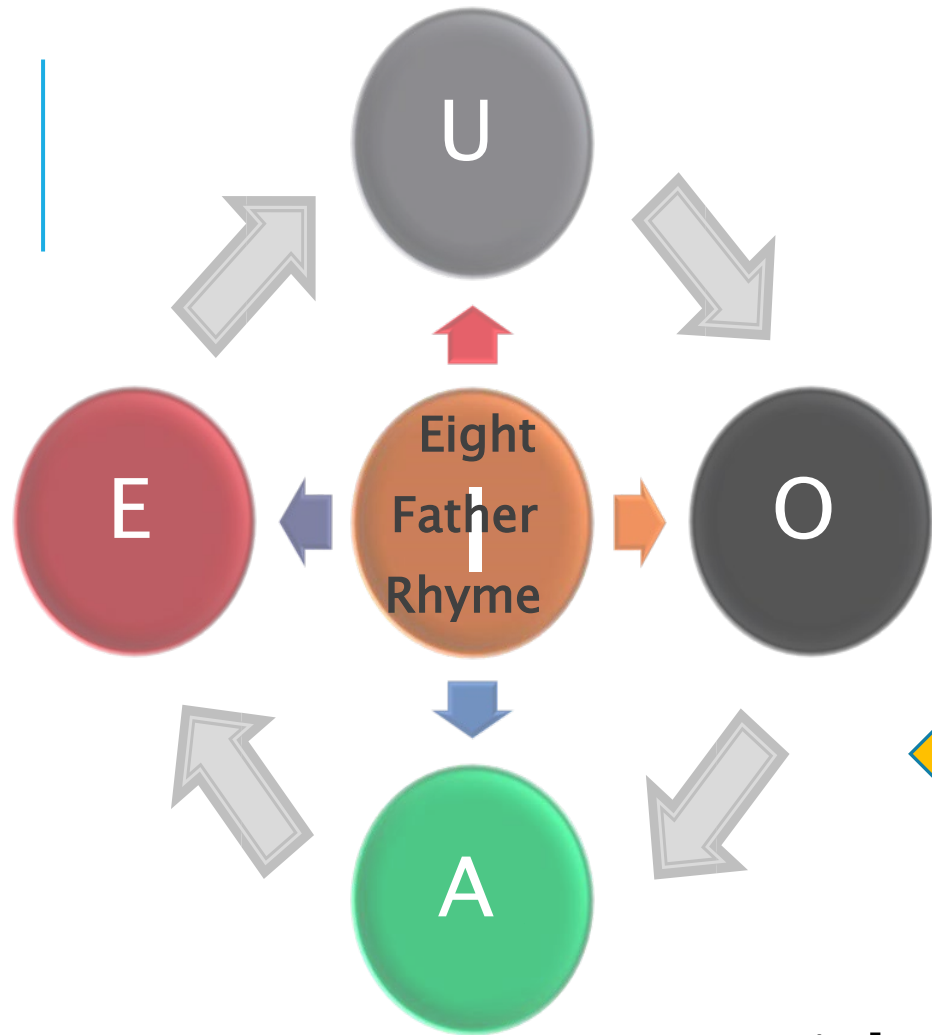

Congenital Structure
Ipsum Esse

Eight father Ki rhyme

Time

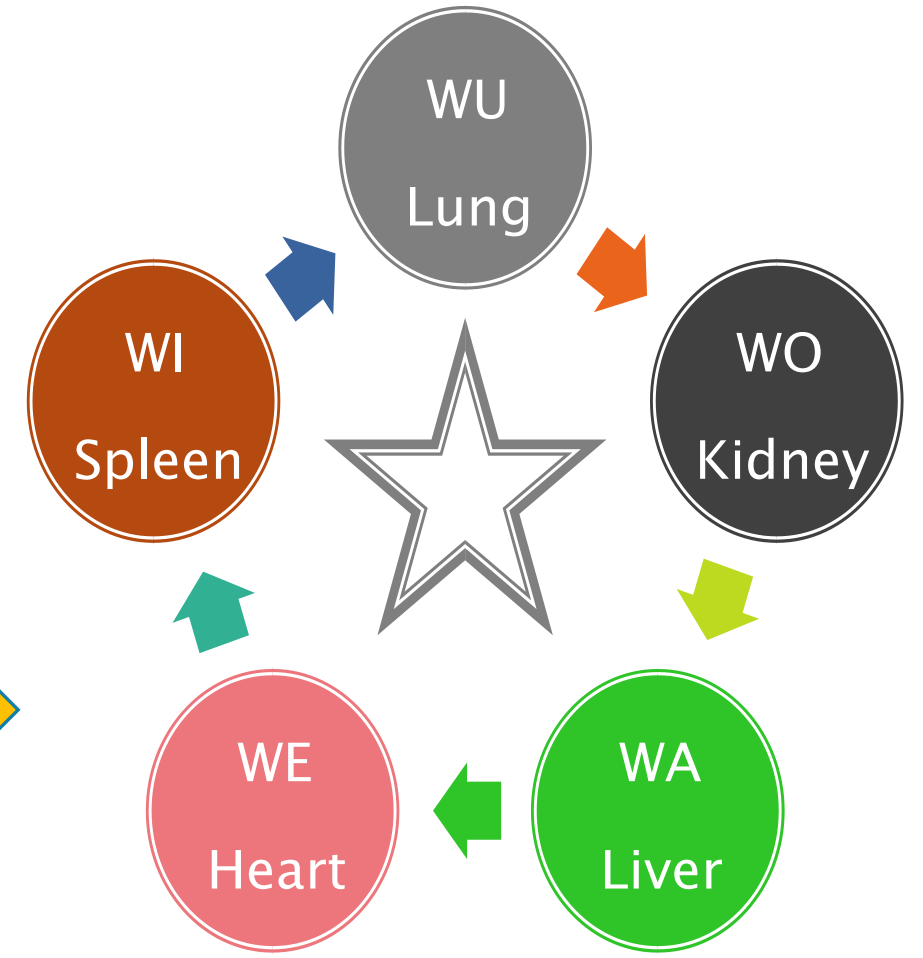

Acquired Structure
Space

Meridian

* HARI SHIMPO

POSTURE AND
KI-BREATHE
(EIGHT FATHER KI RHYME)

U 奇魂 くし、智。神からのメッセージ
O 和魂 にぎ、親。調和とバランス
A 幸魂 さち、愛。幸を感じる
E 荒魂 あら勇。願いを叶え物事を具現化
I 直霊 なおひ、高次の自分、無意識

U - **Metal**: Desire on five senses, Industry, Economy

O - **Water**: Empirical wisdom, Studies, Science

A - **Wood** : Emotion/Love/Space, Art, Religion

E - **Fire** : Practical wisdom of selection, Political Morality

I - **Earth** : Space creation Will, Activate other
four dimensions



ONZU

U Amatsu-Kanagi
▪ A-kasatanahamayara-Wa

O Akatama
▪ A-katamahasanayara-Wa

A Takara
▪ A-takarahasanayama-Wa

E Amatsu-Futorito
▪ A-takamaharanayasa-Wa

I Amatsu-Sugasu
▪ I - any order - Wi

Subject

Objective appearance on Society

A Wood Emotion Art, Religion LR/GB **wa**

O Water Empirical knowledge Studies, Science KD/BL **wo**

U Metal Desire on five senses Industry, Economy LU/LI **wu**

E Fire Practical Wisdom of Selection Political Morality HT/SI **we**

I Earth Space Creation Will
 Activate 4-mother Space with Eight father rhyme SP/ST **wi**

Ki

T

K

M

H

R

N

Y

S

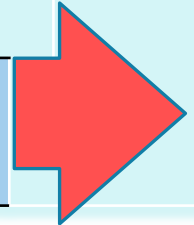

天津 太祝詞 AMATSU-FUTONORITO ONZU

| | T | K | M | H | R | N | Y | S | |
|----------|-----------|-----------|-----------|-----------|-----------|-----------|-----------|-----------|-----------|
| A | Ta | Ka | Ma | Ha | Ra | Na | Ya | Sa | wa |
| I | Ti | Ki | Mi | Hi | Ri | Ni | Yi | Si | wi |
| E | Te | Ke | Me | He | Re | Ne | Ye | Se | we |
| O | To | Ko | Mo | Ho | Ro | No | Yo | So | wo |
| U | Tu | Ku | Mu | Hu | Ru | Nu | Yu | Su | wu |

The Flow of the KI 

YATA NO KAGAMI

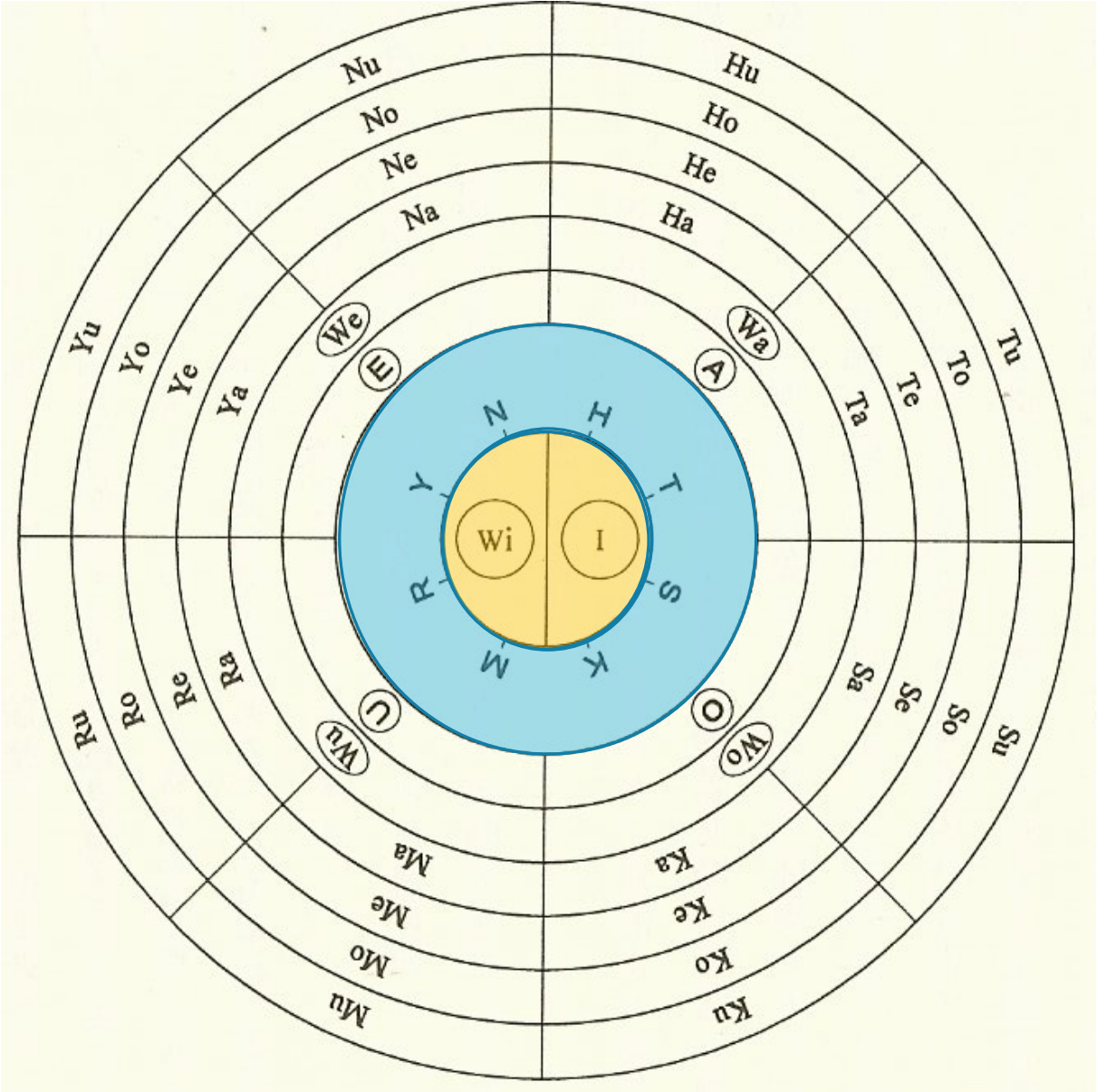

THE PILLAR OF THE HEART

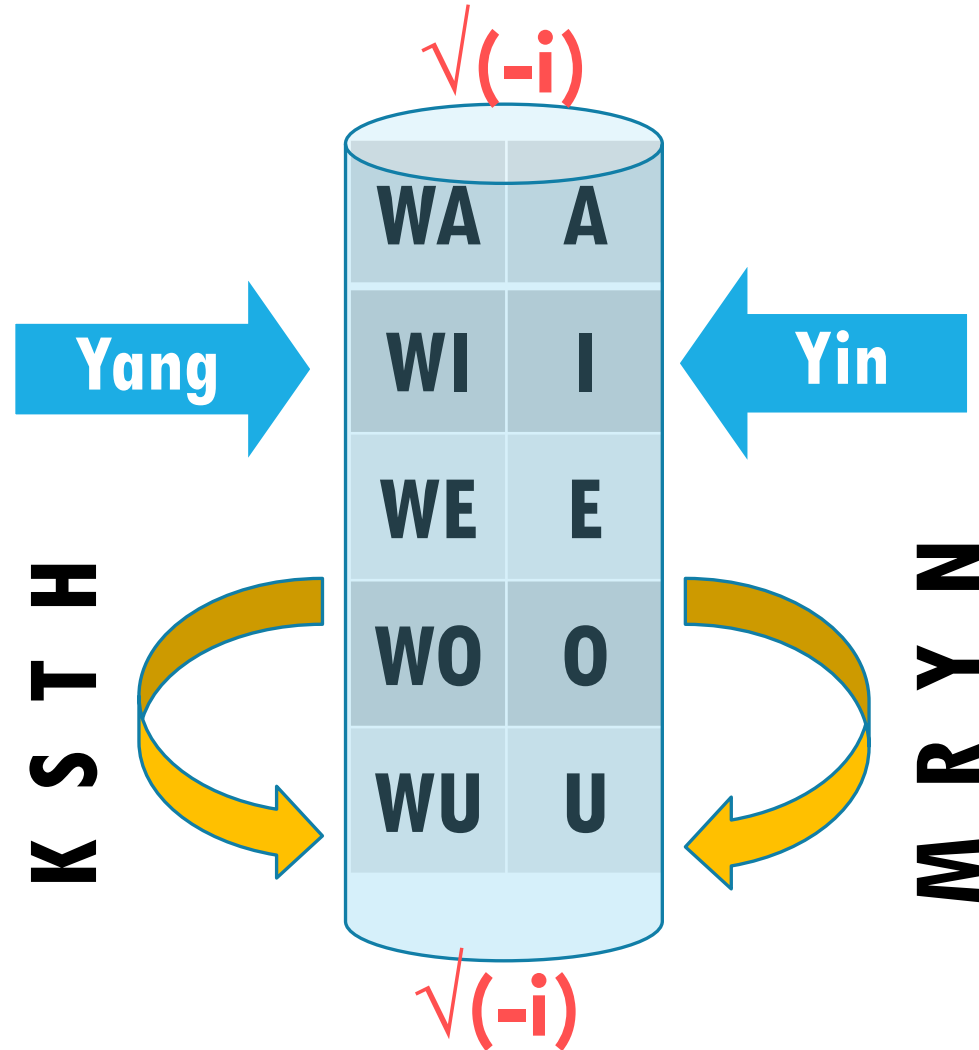

HARI ROOT TREATMENTS

SHO/ DX. AND POINTS

Step 1, 2 and 3.

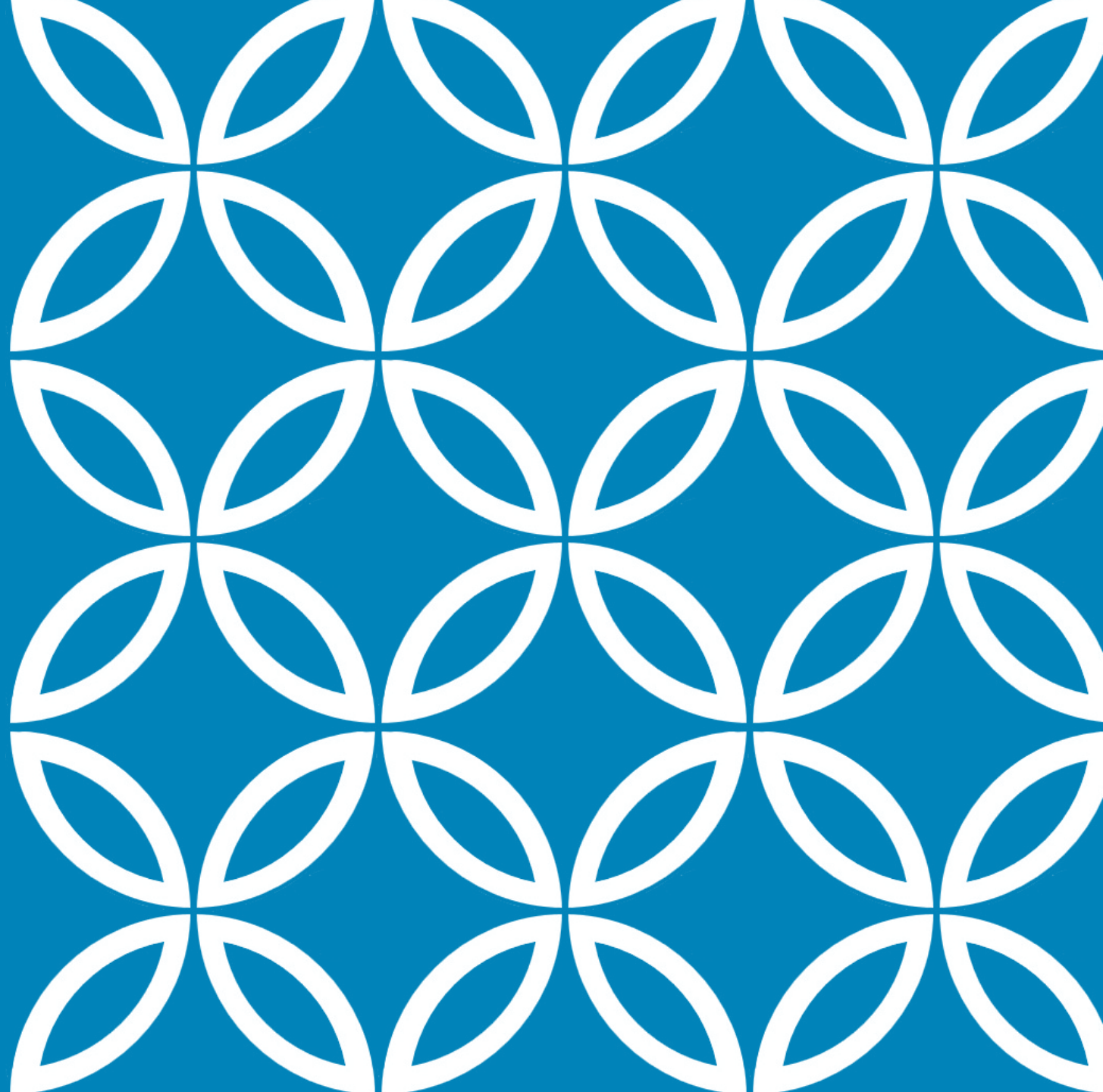

* **HARI**
TX. STEPS

ROOT TX.
STEPS 1

2

3

- **Stp 1. Primary SHO,**
Five-dimensional Spiritual Pattern
Intuitive dx. (A-Ha) and Six-Comparative Pulse dx.
w/Principles of tx.
- **Stp 2. Secondary SHO,**
Pathological (Physical Body) Pattern
Effects on Meimon (Life of gate) with Jaki as
excess in body. Pulse (Quality dx.)
- **Stp 3. Yang meridians**

□. TX. SIDE
AND
MAIN TX. POINTS

□ w/ KISHIN DX.

❖ Deficiency, tonify source, 5 phase pt. on side. same as pulse or/and Kishin dx.

❖ Excess, disperse pts. on same side that effected from Jaki.

use Luo point. if symptoms is severe can be used Xi-Cleft pts.

**□. HOW TO
FIND**

**DEFICIENT
POINT**

- ❖ The deficient point is sticky, depressed or weak.
- ❖ Those area with no energy flow appears dark.

**□. HOW TO
FIND**

**EXCESS POINT
AND
JAKE INVASION**

- ❖ The point that was affected from Jaki is unsmooth, convexed or hard, rough.
- ❖ Those area with energy flow appears as darkness and volcano/tornado pattern.

HARI TREATMENT

“ HARI SHIMPO ”

Nenshin (1)(2) with Kototama

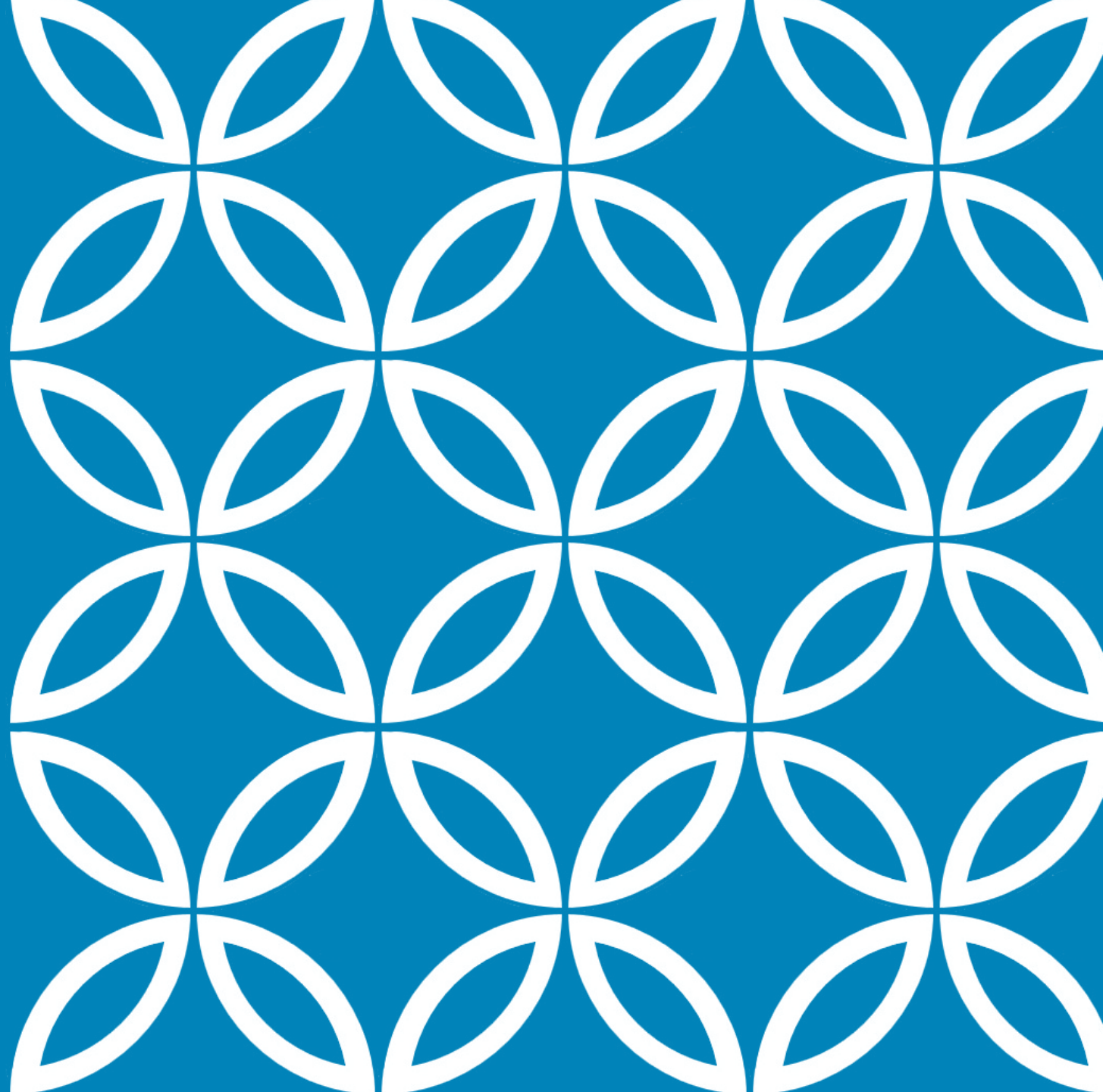

HARI SHIMPO

KEY POINTS

Kototama Hari Practice

1. Conscious-Intension:
 - Power of Words and its effect
2. Ki-Breath and Body Posture
3. Gassho-Gyoho
4. What is a Kundalini? and Its effects on body.
5. Nenshin (1) (2)



HARI SHIMPO

KEY POINTS

Kototama Hari Practice

- 6. Hari needling**
 - Shape, Positioning of Body Posture
 - Oshide/ L-hand
 - Sashide/R-hand

- 7. Timing for going and removal within inlightment.**

*** HARI
SHIMPO**

**POSTURE AND
KI-BREATHE
(AI-GASSHO GYOHÔ)**

U - upward

O - down

A - front

E - back

I - ***Center**

Start from * End in * **Middle-Tanden** (Between
CV18 and **GV11**)

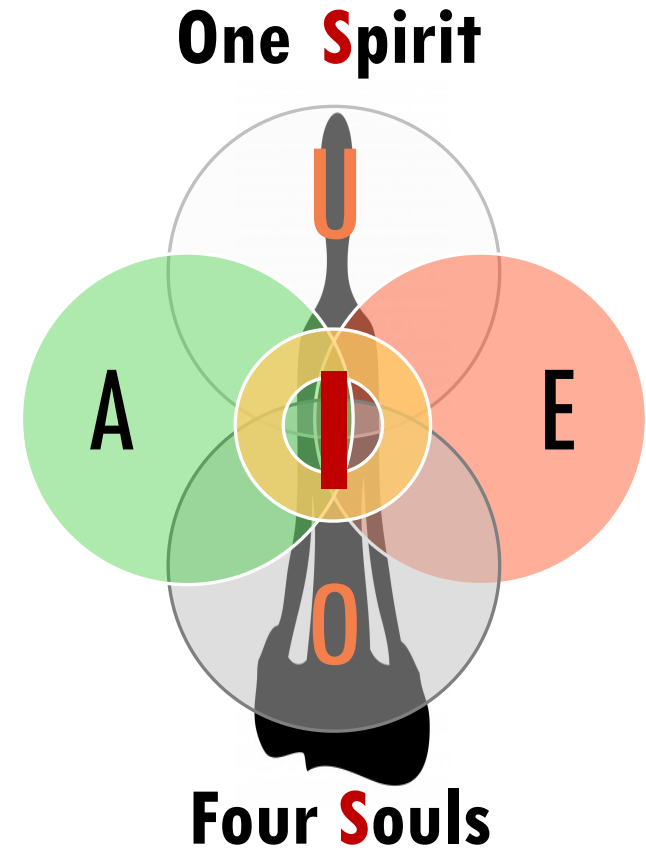

HARI SHIMPO

AI-GASSHO GYOHÔ

(**AI** 愛-LOVE) = “SPACE”

AI IS THE LOCUS OF FEELINGS
OF SPACE WILL (**I**).
IT IS PASSION, 愛-LOVE.

A IS “WOOD” ELEMENT AS
BLOOD/MEIMON-FIRE WITH
SPACE WILL (**I**) IN BODY .



HARI SHIMPO

KI-BREATHE WITH KUNDALINI

AI-GASSHO GYOHÔ

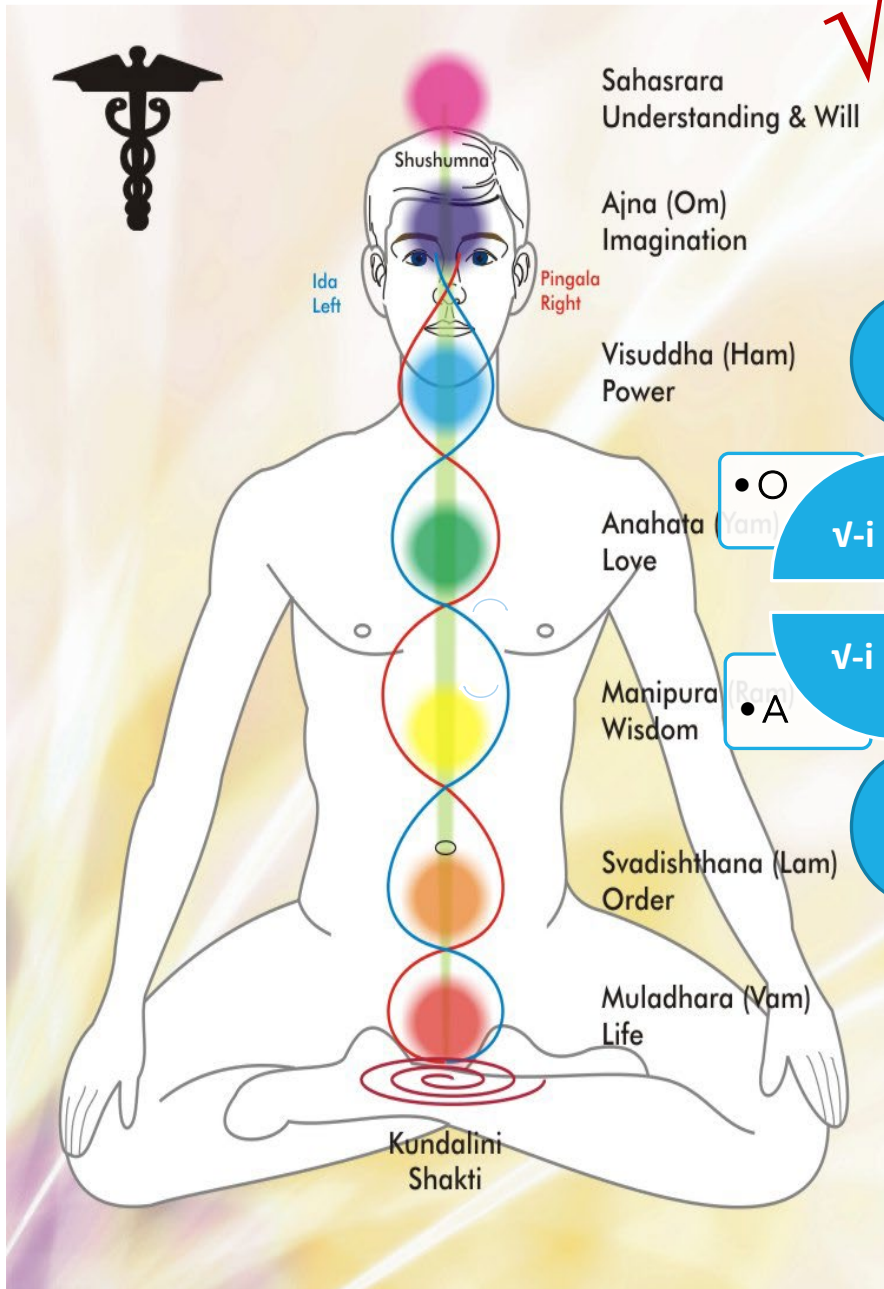

✓- i

Major Endocrine Glands

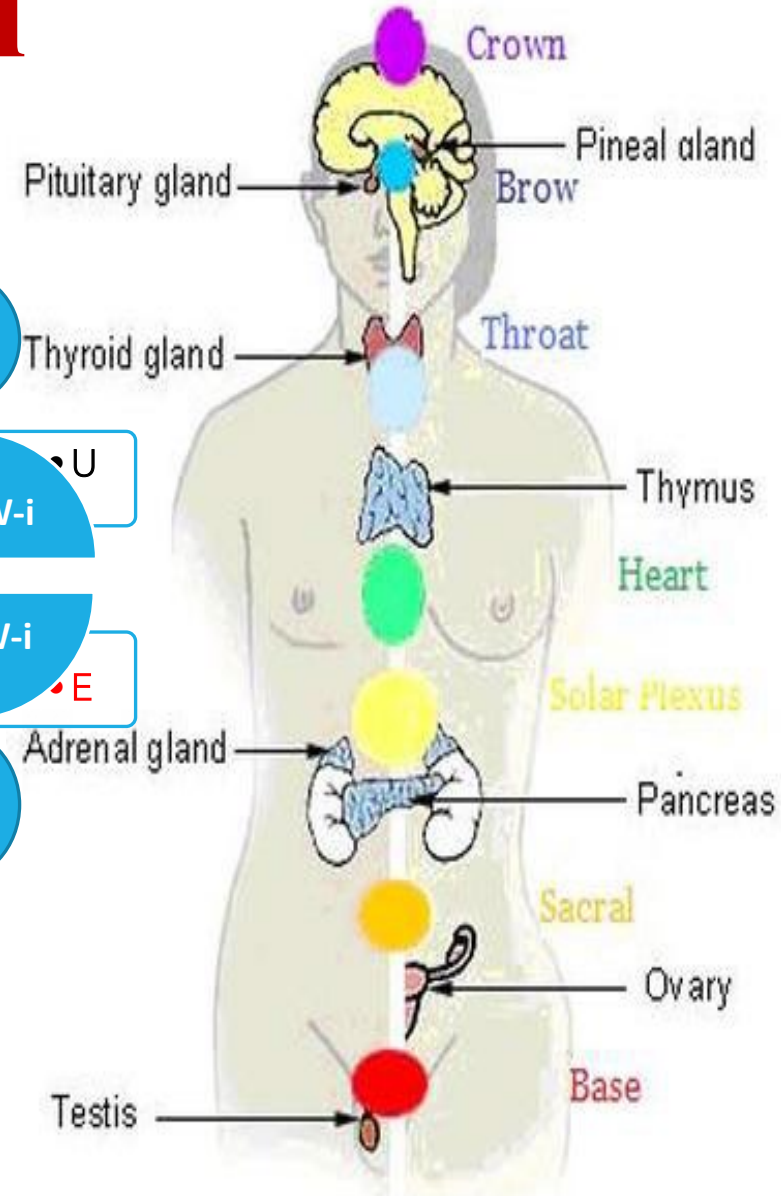

**HARI
SHIMPO**

TONIFICATION

❖ **Ho-ho**

Creation of the Light

Effect of the tx. come with **Nen-Shin (1)**

Method

a- Quality

b- Quantity of the Ki and

c- Points, Oshide-Sashide

.

TONIFICATION WITH $\sqrt{-I}$

$\sqrt{-i}$

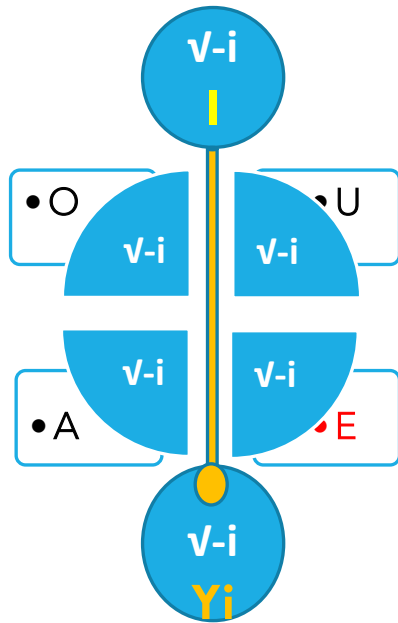

Step (1)

Pressure from center of your finger

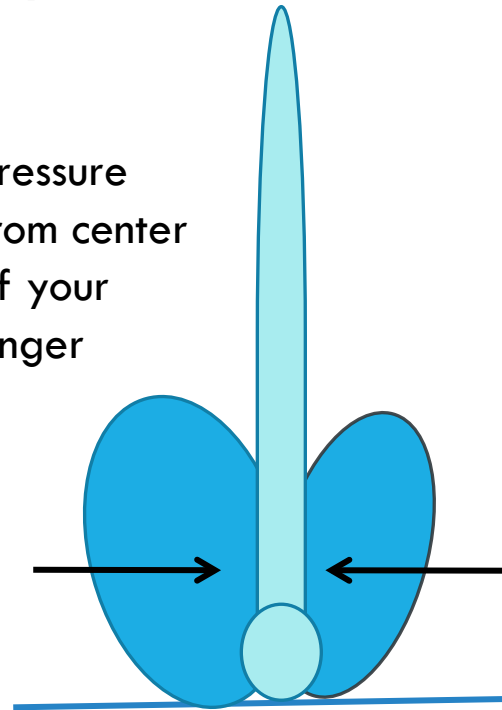

Beginning of Tonification

Step(2)

Pressure from upper side of your finger

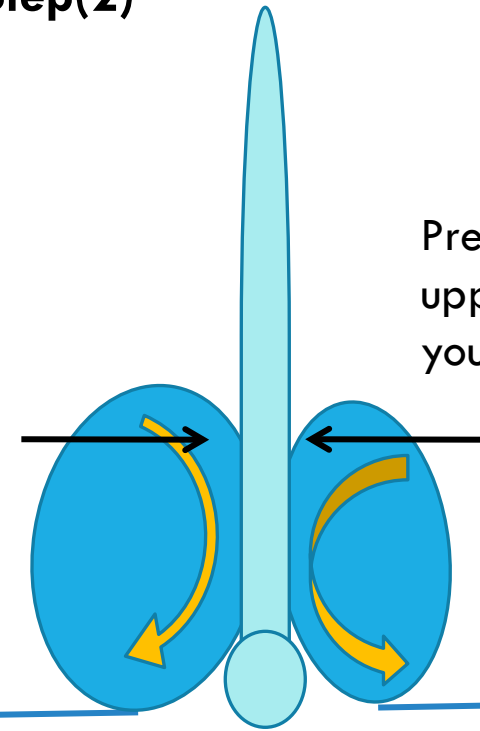

and removal

**HARI
SHIMPO**

**DISPERSION
(MISOGI)**

❖ **SHA-ho**

Sha-ho retune the rhyme/ (Eight Father Ki Rhyme) and Time.

1. Release the attachment on the meridian that disharmonized the nature.

HARI SHIMPO

DISPERSION
TECHNIQUE

(2) SHA FOR JAKI

Two type of Excess (Jitsu)

(1) Oki-Jitsu

Natural Excess without Jaki

(2) Jaki-Jitsu

Excess, effected by Jaki.



JAKI

DISPERSION

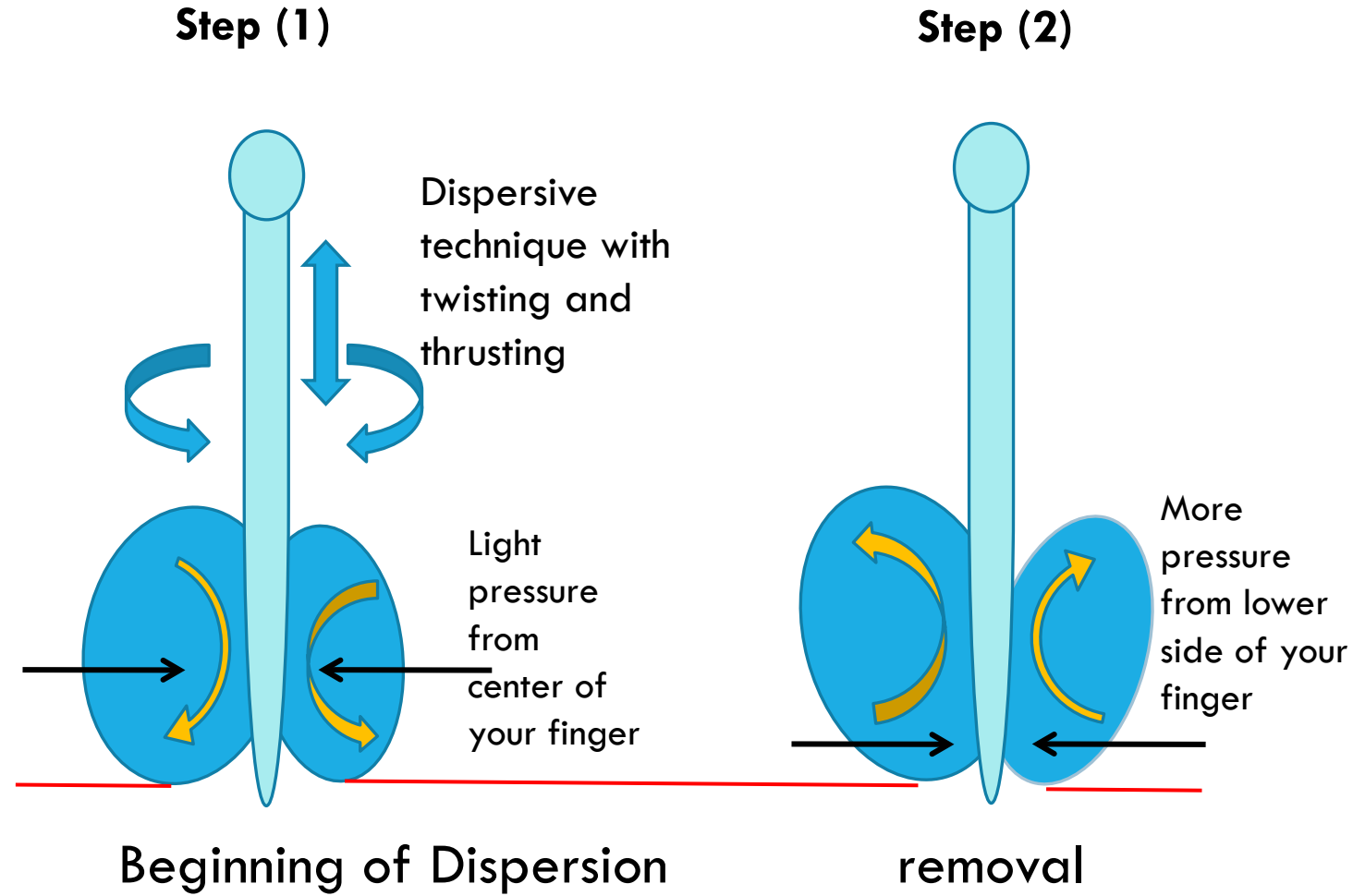
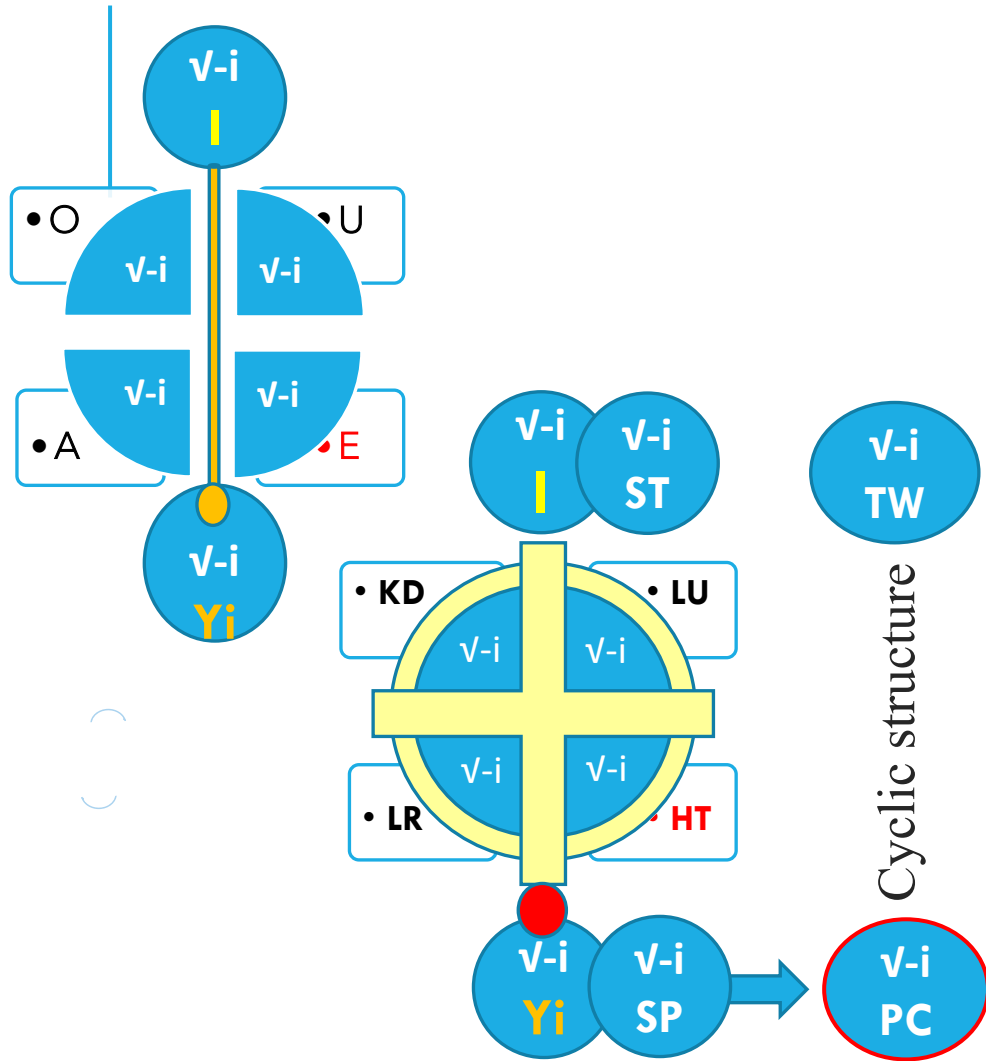

DISPERSION WITH MÖBIUS

Möbius Dispersive
technique with 4-
Dimensional twisting and
thrusting

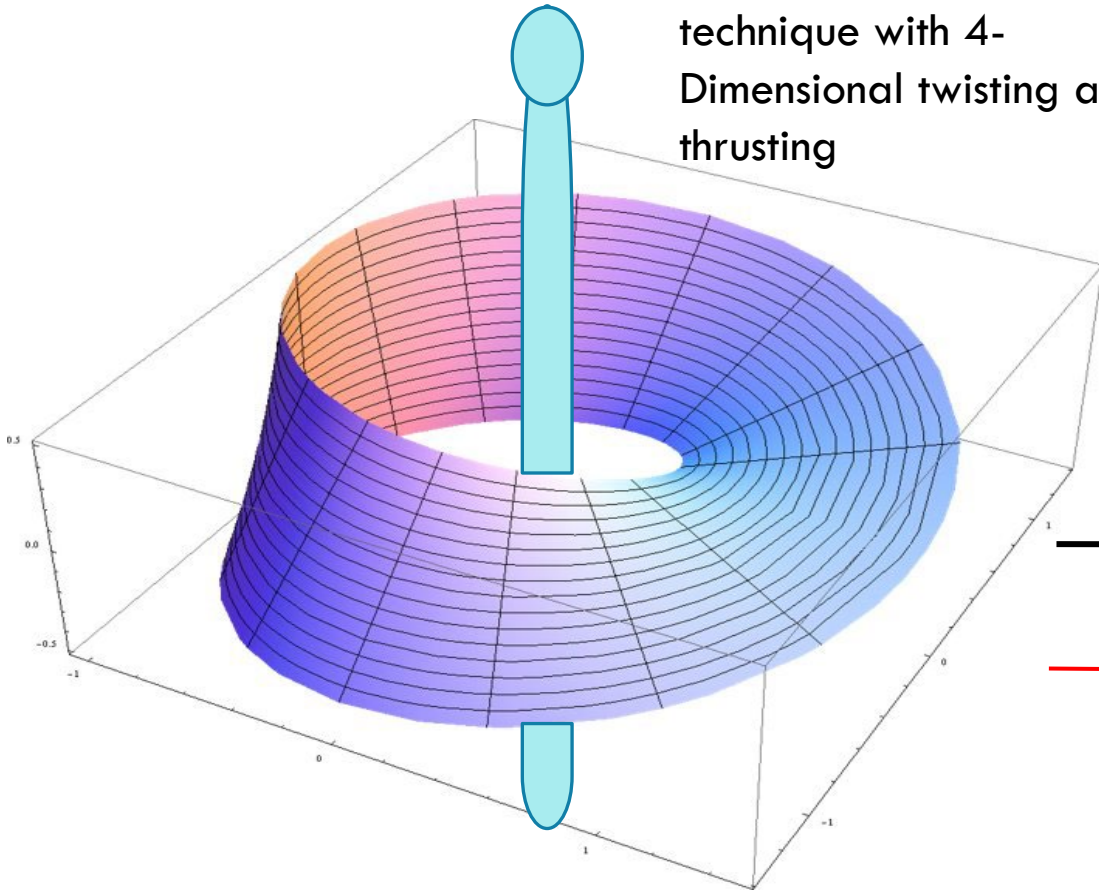

Step (1)

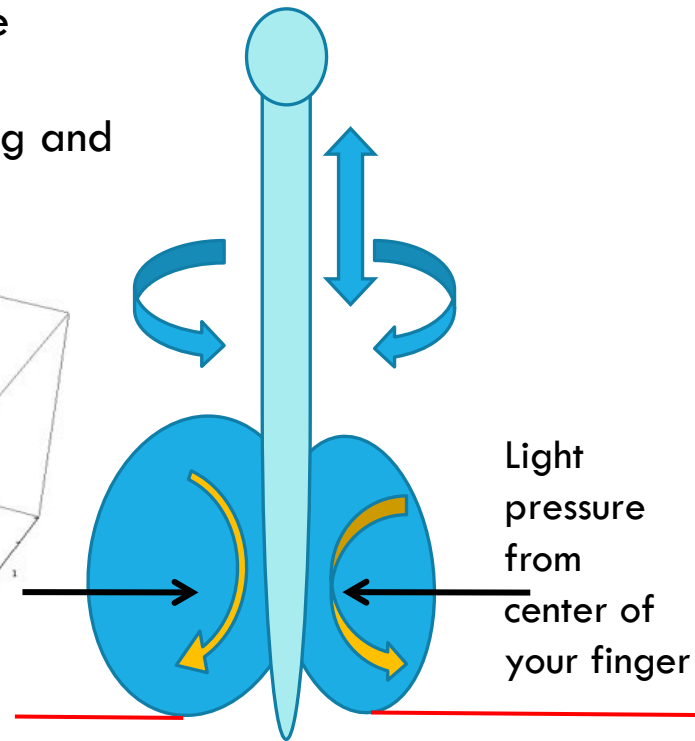

Beginning of Dispersion

Step (2)

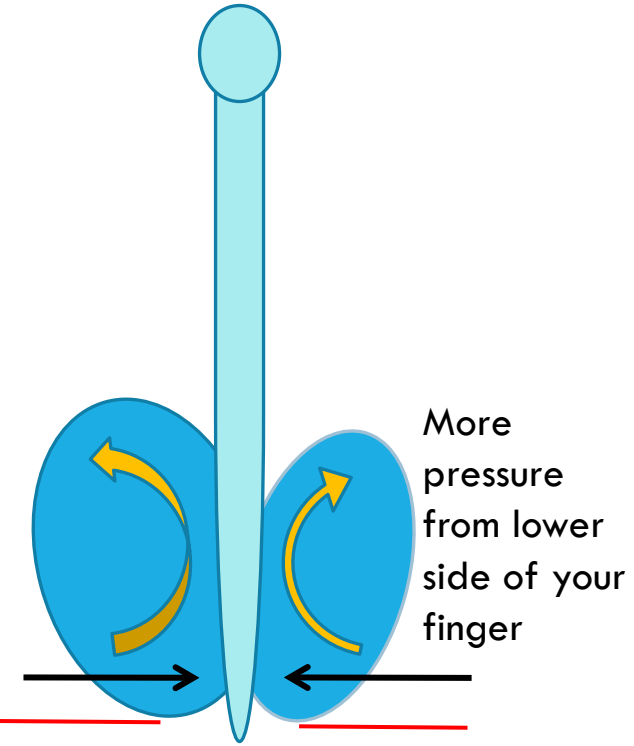

removal

HARI PULSE DIAGNOSES

Stomach Pulse and depth of the pulse position

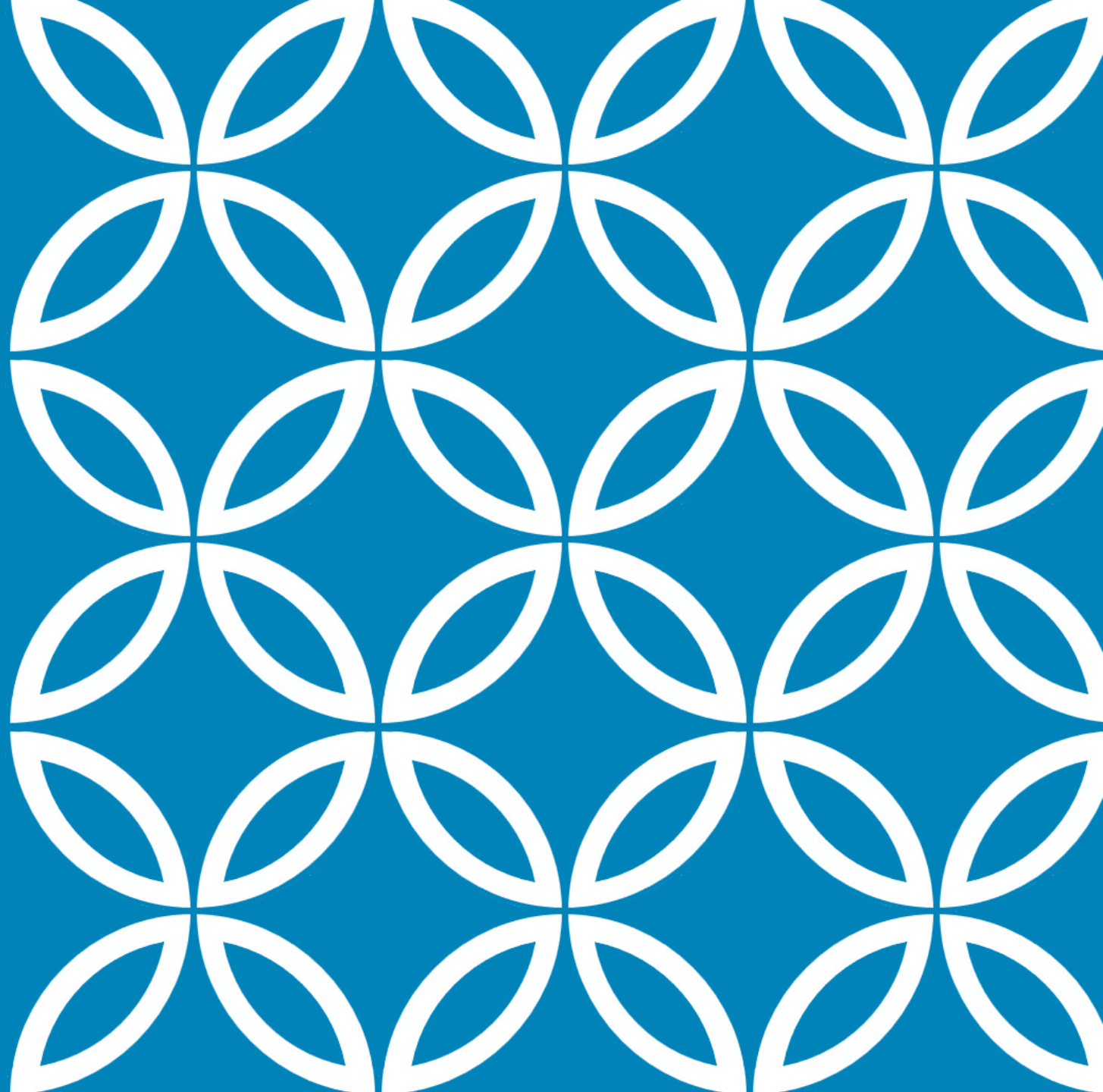

PULSE DX.

POINTS
TO
UNDERSTAND ABOUT
STOMACH
(CALM) PULSE QUALITY

1. ST Ki can be judged as being abundant if the pulse has enough depth (thickness) in between the superficial and deep levels.
2. ST Ki quality should feel as moderate and peaceful. * *Myakutei*

PULSE DX.

SIX COMPARATIVE PULSE Dx.

FOR PRIMARY SHO

MIDDLE PULSE

- A)** Middle pulse is the line where the three fingers feel equally and clearly the pulse.
- B)** It is also the place where the pulse is felt the strongest.

- ❖ First, Find the Middle Pulse, then**
 - 1.** Compare the Yin/Yang,
 - 2.** Find deficiency/excess (Oki or Jaki-jitsu)
in the 6 positions.

PULSE DX.

PULSE QUALITY Dx.

FOR **SECONDARY** **SHO**

- Locate the abnormal pulse that is come with **Pathological** effects from **Jaki** invasion.
- 1. Detect the Jaki Ki in pulse that is missing the ST Ki pulse quality.
- 2. It shows the Hesitate pulse that caused by excess or deficient type of Jaki.

PULSE DX.

□ Use the pulse quality + sense dx.

FEEDBACK METHODS

WITH

1. PULSE QUALITY

2. 6TH - 7TH SENSE

:

1. For more than just identifying SHO/
pattern of disease.
2. It can be used as a feedback method,
assessing the effectiveness of the tx.
as it is being given.

HARI LOCAL TREATMENTS

Volcano and Sanshin
Step 0, 4 and 5.

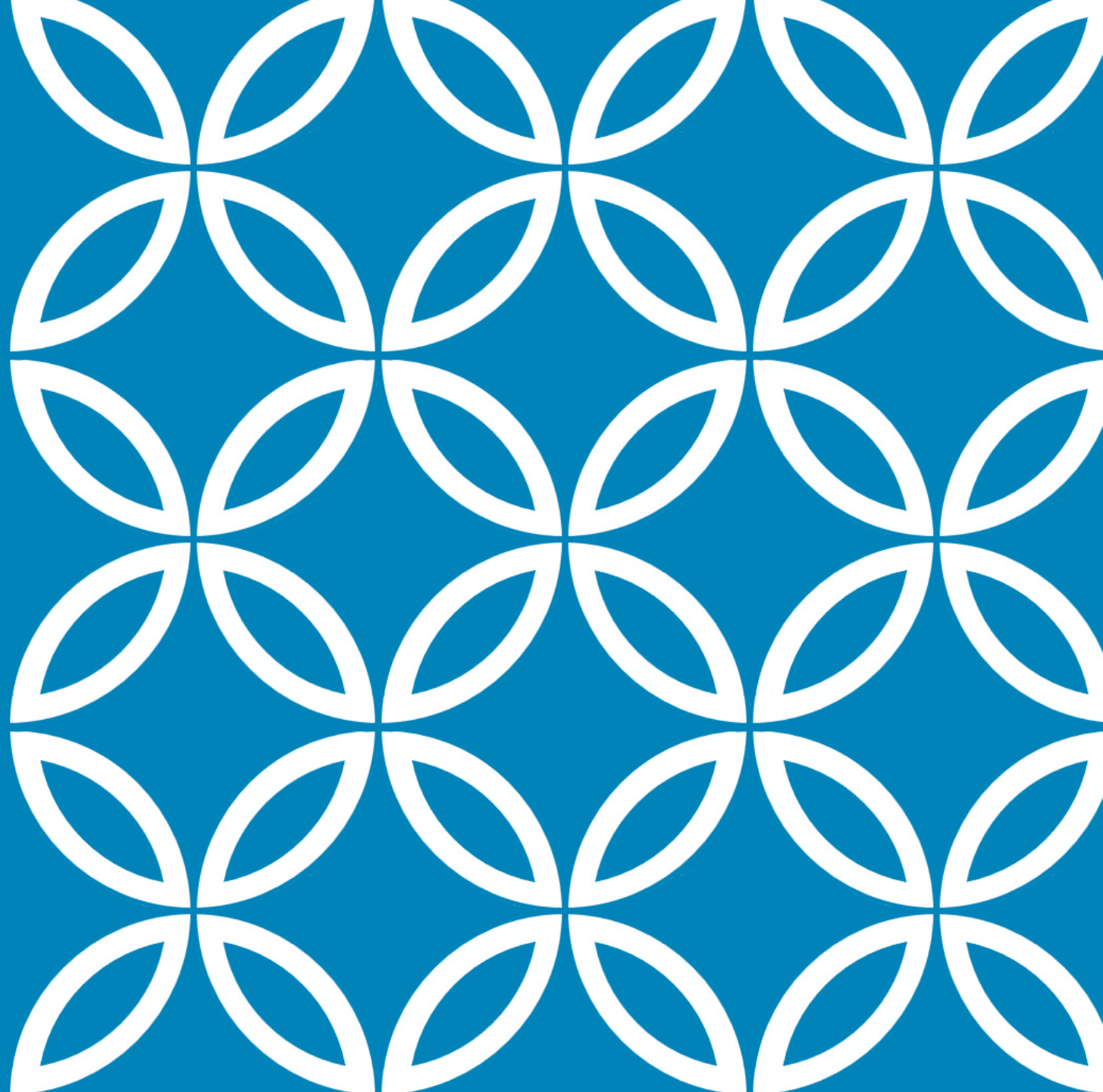

* **HARI**

**ORDER OF
LOCAL TX.**

STEP. 0

. 4

. 5

0 and 4

[A] Thoracoabdominal, Back Region and
Supplementary systems & Local points

[B] Affected Area

[C] Harmony points

5 [A] Finish needling

[B] Moxibustion

[C] Home treatment

* **HARI**
LOCAL TX.

STEP **0**, **4** AND **5**:

- A: **Supplementary** systems
(EV, Shigo, Shiraku, Ketsubon/Kigai...)
- B: **Volcano** point tx. w/Nenshin(2)
Sanshin tx. (Hifushin, Piano touch....)
- C: **Harmony** Points
- D: Home therapy
(Moxa, Magnet, Pressball...)



HOW TO FIND

EXCESS POINT

- ❖ **Dispersing point (Volcano/Tornado)**
has a resistance (losing flexibility).
 - Usually feels drier and tighter like a wall.

WHAT IS
VOLCANO PT.

- 1) Volcano point tx.:** w/Nenshin (2)
- 2) Sanshin tx.**

Excess type of skin was helped with
Hifushin, Piano touch

SANSHIN TX.

Scattering Needle (San-Shin)

JAKI EFFECTS, PROGRESSION OF THE JAKI INVASION

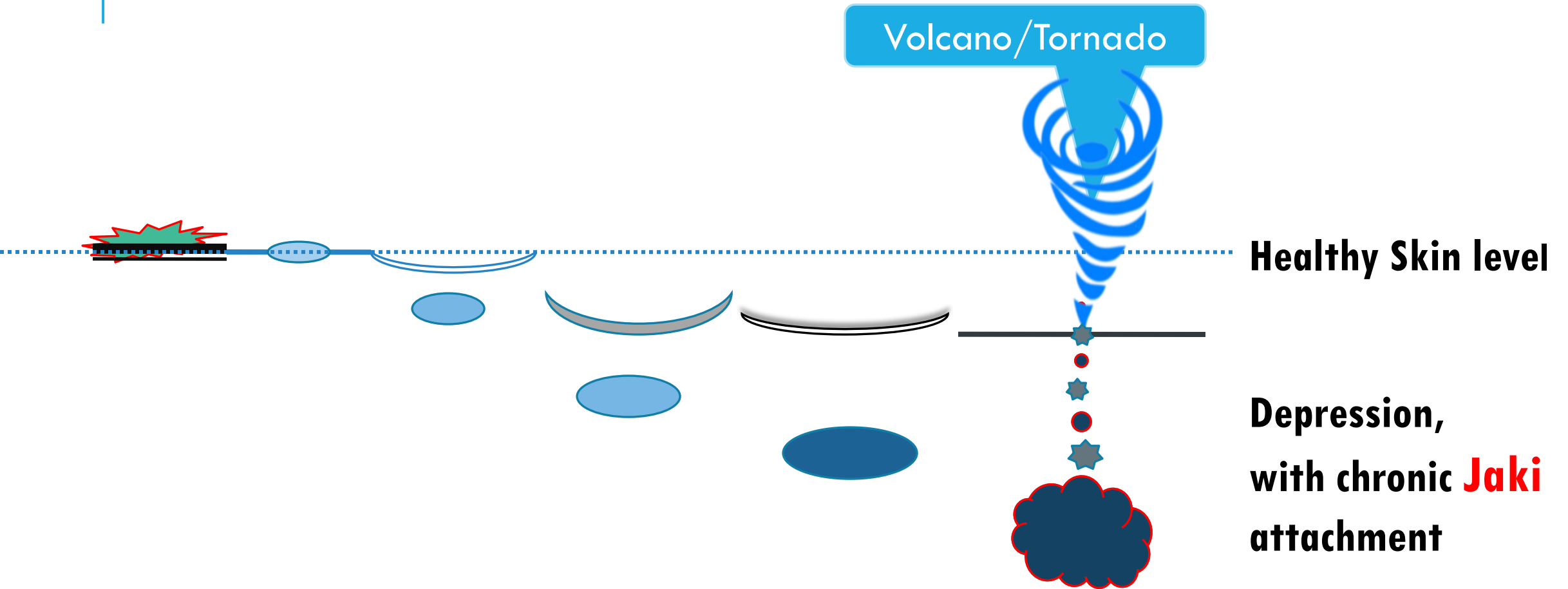

* **LOCAL TX.**

W/VOLCANO TX.

STEPS: 0. 4. 5.

Volcano, live-point

has a kind of connection to **Jaki**.

Under the point-surface, it likes an old thread and induration.

It helped by three types of tx. methods corresponding to their skin, old thread conditions.

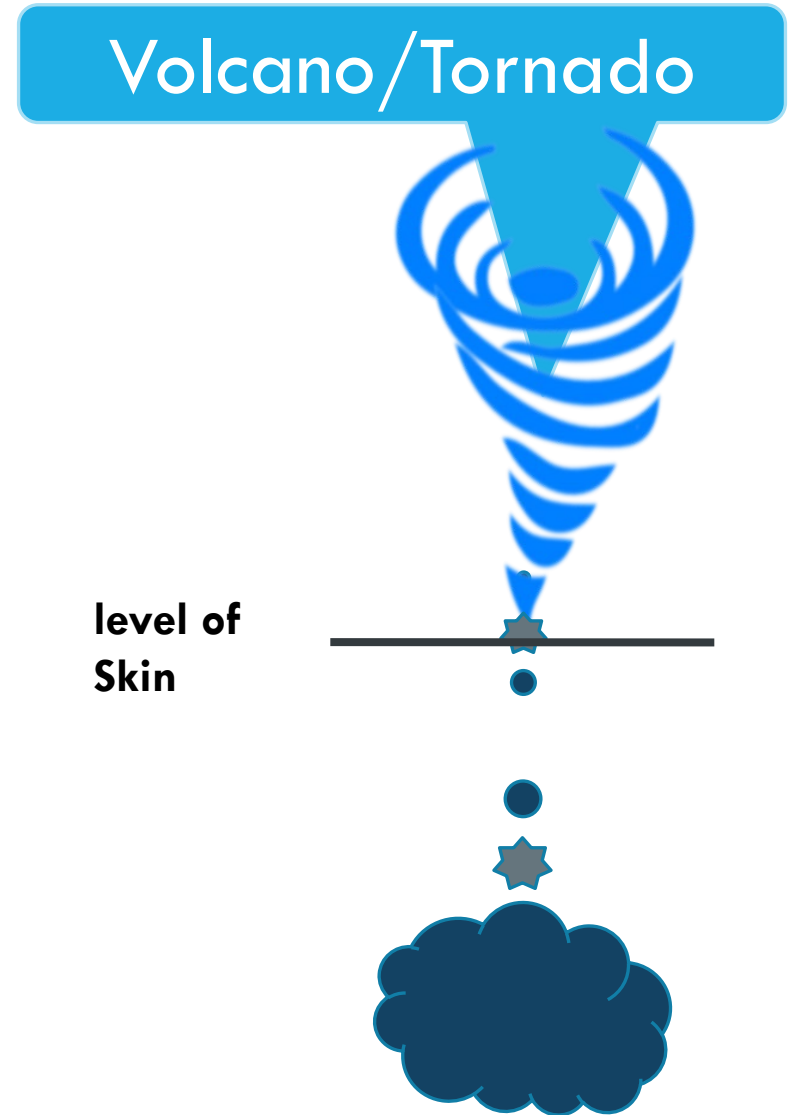

live-Volcano point with Jaki

* LOCAL TX.

VOLCANO TX.

STEPS: 0. 4. 5.

| | Level of Water | Surface | Thickness of the skin |
|------------------------|-----------------|--|-------------------------------|
| (1) Sanryo-Shin | Dry | Convex | Thick, hard, rough |
| (2) Go-Shin | Med | -level | or mix |
| (3) Chokusetsu -Kyu | Dampness wet | Concaved depressed soft, flaccid | Thin, with water retention |